



Kalamazoo County

Health & Community Services

KALAMAZOO COUNTY ENVIRONMENTAL HEALTH BUREAU
3299 GULL ROAD, P.O. BOX 42 NAZARETH, MI 49074-0042
PH: 269-373-5210 FAX: 269-373-5333
Website: www.kalcounty.com/eh

Reference Manual

Introduction

This manual is designed to assist in achieving greater uniformity in the plan review process by providing technical assistance for design professionals, owners and others in the preparation of food service plans and completion of the plan review worksheet. Individuals who have questions during the plan review process should call the local health department or Michigan Department of Agriculture office that will conduct the plan review. Agency contact information is available at: www.kalcounty.com/eh

Plan review of *food service establishments*, retail food stores, and all other food operations, is a high priority for Michigan Department of Agriculture and Michigan's local health departments.

A good review of plans helps to avoid future problems. By listing and locating *equipment* on floor plans and diagramming specifications for electrical, mechanical and *plumbing systems*, potential problems can be spotted while still on paper and modifications made **before** costly purchases, installation and construction.

Food establishment plan review is recognized as an important food program component that allows:

- Regulatory agencies to ensure that *food establishments* are built or renovated according to current regulations or rules
- Industry to establish an organized and efficient flow of food
- Regulatory agencies to eliminate code violations prior to construction

Who Must Submit Plans?

An application for a food establishment license must be submitted to the appropriate regulatory agency at least thirty days before a new food business opens. An inspection must be conducted before a license can be issued. When plans are required, these plans must be approved prior to construction or remodeling! The agency conducting the plan review must complete the review within 30 business days of receiving complete plans. Plan review fees vary among local health departments. The following establishments are required to submit plans for review and approval:

- Food service establishment (local health departments - fees vary).
- Extended retail grocery (MDA - no added fee).
- Special transitory food unit (local health departments or MDA - fees vary).
- Mobile food establishment (local health departments or MDA - fees vary).
- Other MDA-licensed retail establishments are encouraged to avail themselves of MDA for plan review services at no added cost. (These fees have already been built into the license fees.)

The Michigan Food Law of 2000 and the 1999 Food Code, which is adopted by reference and is a part of the Michigan Food Law, is used as a reference in completing this guide. To view the food code, food law and other fact sheets go to:

<http://www.michigan.gov/mda>, keyword: MFLeduc, or call 517-373-1060 to request free single copies.

Defined words are *Italicized* in the text of the manual.

Table of Contents

		Page
Introduction	Who must submit plans?	Inside Cover
Suggested Changes	Form	4
Plan Submittal	Documents Required	5
Plan Review Process	Flow Chart	6
SOP's	Standard Operating Procedure Instructions and Guidance	7
Part 1	Menu Consumer Advisories Food Flow	20
Part 2	Handwashing	23
Part 3	Facilities to Maintain Product Temperature	24
Part 4	Facilities to Protect Food	28
Part 5	Water Supply & Sewage Disposal	29
Part 6	Food Equipment & Installation	34
Part 7	Dry Storage	37
Part 8	Sinks Warewashing Facilities	40
Part 9	Hot Water Supply Requirements	44
Part 10	Finish Schedule/ Floors, Walls & Ceilings	47
Part 11	Toilet Facilities	49
Part 12	Plumbing Cross-Connection Control	49
Part 13	Insect & Rodent Control	60
Part 14	Lighting	60
Part 15	Ventilation	61
Part 16	Dressing & Locker Rooms	62
Part 17	Garbage Refuse Storage	63
Part 18	Special Transitory food Unit (STFU)	63
Part 19	Non-Smoking Area and Choking Poster	67
Part 20	Definitions (Defined words are <i>italicized</i> in the text)	68
References		71
Acknowledgements		72

Food Establishment Plan Submission Instructions

Congratulations! You are proposing to build or remodel a food establishment in Michigan. Please submit your plan review package to the local health department or Michigan Department of Agriculture regional office that will be conducting the plan review. All of the following items must be completed and compiled into a single package or the plan review may get delayed as additional material is requested. For further information, see the plan review manual.

1. Plan Review Application

2. Any necessary plan review fees. Contact your local health department or regional MDA office for the applicable fee.

3. Completed Plan Review Worksheet

- Worksheet and guidance manual copies are available from any health department, MDA Regional Office or on the web at: <http://www.michigan.gov/mda>.

4. Menu

- If your facility does not have a formal, set menu, such as a school with a rotating menu, submit representative sample menus or a list of foods offered for sale or service.

5. Standard Operating Procedures (SOP's)

- SOP's appropriate to your operation shall be submitted prior to opening. See the SOP instruction sheet.

6. One Complete set of plans. (note: some local health departments require two sets of plans). Provide scaled plans (1/4" per foot is a normal, easy to read scale). Show:

- Proposed layout, with equipment identified. Label sinks and prep tables with their intended use.
- Mechanical plan (i.e. make-up air systems, air balance schedule and cooking ventilation systems: including hood, duct and exhaust fans).
- Plumbing: Sinks for handwashing, food preparation and dishwashing, dishmachines, hot and cold water outlets, hot water equipment, water heater, sewer drains, grease traps and floor drains / sinks.
- Construction materials of such items as custom cabinets and any other built-in items.
- Interior room finish schedules.
- Lighting plan, indicating which lights are shielded.
- Site Plan, including:
 - Details of outside garbage storage area and containers, as well as exterior storage areas.
 - On-site water well and sewage disposal system data

7. Specifications

- Include manufacturer's specifications for each piece of equipment. Minimum information for each piece of equipment includes the following (note: the manufacturer's specification or "cut" sheet typically provides most of this information):
 - Type
 - Manufacturer
 - Model number
 - Dimensions
 - Performance capacity
- Indicate how equipment will be installed (i.e. on leg or wheels, fixed or flexible utility connections)
- Indicate which items are used equipment and what equipment is NSF approved or equivalent.
- Sanitation Standard Operating Procedures (SSOP'S): Include any available cleaning and maintenance instructions for food processing, cutting and grinding equipment.

Plan Review Process Flow Chart

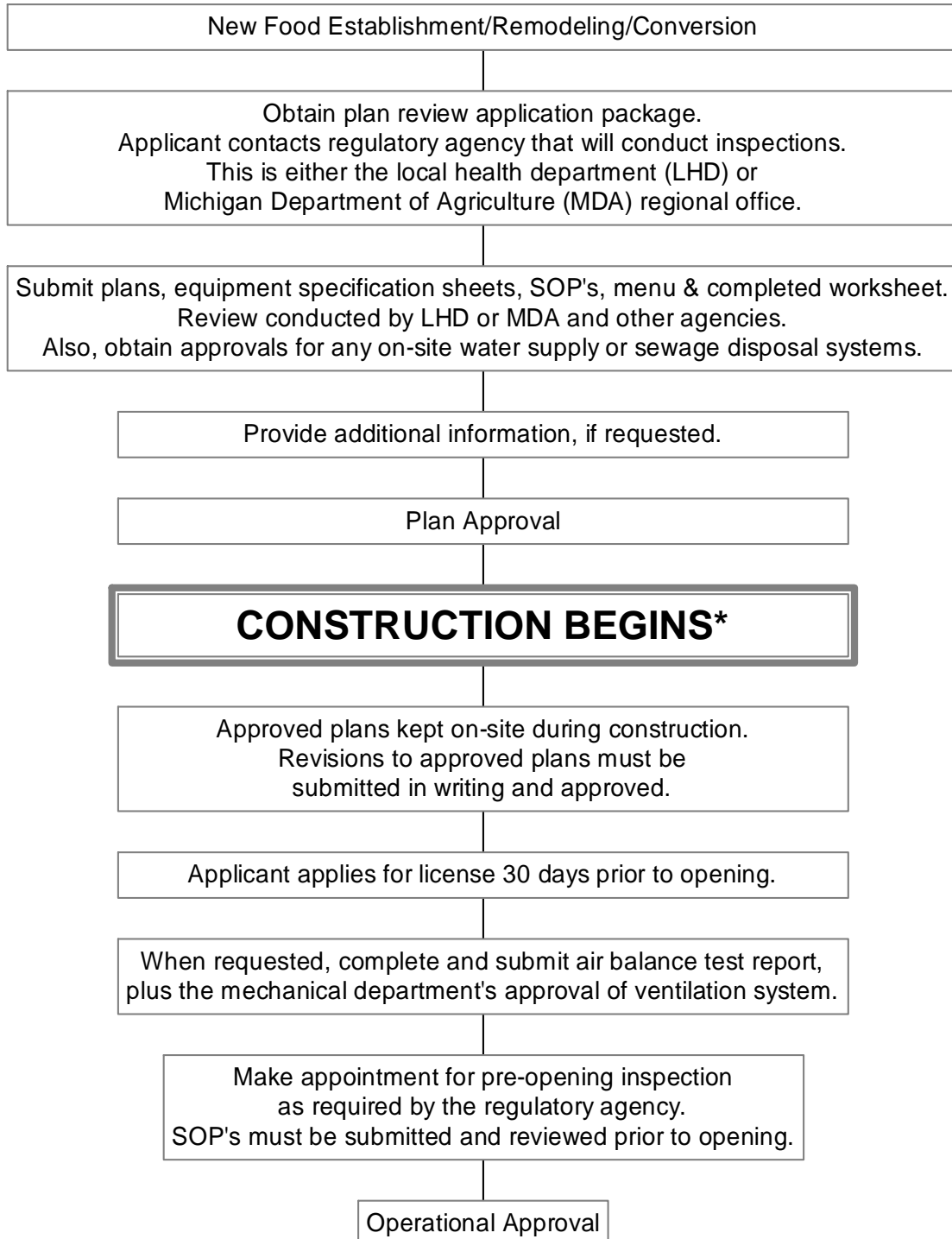

*Agencies have the authority to issue a stop work order when construction begins before plans are approved.

Food Establishment Standard Operating Procedures

Who must have standard operating procedures?

- All new food establishments, except vending locations.
- Remodeled food establishments that change menu or operation.

What are standard operating procedures?

- Procedures specific to your operation that describe the activities necessary to complete tasks in accordance with the Food Code. The procedures are used to train the staff members responsible for the tasks.
- Three purposes for establishing SOP's for your operation are: to protect your products from contamination from microbial, chemical, and physical hazards; to control microbial growth that can result from temperature abuse; and to ensure procedures are in place for maintaining equipment.

Why must procedures be submitted?

- Michigan's food law requires standard operating procedures to be established prior to opening.

How must procedures be developed?

- Procedures are mostly for use by managers and employees. Develop procedures in the language, style and format best for the establishment. An English copy of the procedures is needed for the plan reviewer.
- For those that need assistance, see the help section.

What procedures must all establishments submit?

- Handwashing.
- Personal hygiene, including cuts and sores.
- Preventing bare hand contact with ready-to-eat food (gloves, utensils, etc.).
- Employee illness.
- Purchasing food from approved sources.
- Cleaning and sanitizing food contact surfaces.

What procedures must all establishments submit when applicable to their operation?

- Cross-contamination prevention.
- Warewashing.
- Date-marking ready-to-eat, potentially hazardous food.
- Using time only (not time and temperature) as a method to control bacterial growth.
- Time and temperature control for thawing potentially hazardous food.
- Time and temperature control for cooking potentially hazardous food.
- Time and temperature control for cooling potentially hazardous food.
- Time and temperature control for reheating potentially hazardous food.
- Time and temperature control for hot holding potentially hazardous food.
- Time and temperature control for cold holding potentially hazardous food.
- Special transitory food units (SFTU's) only- water supply.
- Special transitory food units (SFTU's) only- wastewater disposal.

Once procedures are developed, where should they be sent and what happens to them?

- Procedures should be sent to the agency reviewing the plans as soon as they are ready.
- Procedures can be sent with the plans or may be sent later.
- Technically correct procedures must be in place by the pre-opening inspection.
- Plan reviewers will make sure the information in the procedures is correct. Be sure to leave enough time to make corrections. Contact your plan reviewer for help.
- Procedures should be kept on-site and used by the person in charge and employees.

Standard Operating Procedure (SOP) Writing Help

For establishments that need help in writing a standard operating procedure, this section contains:

- Blank forms in a suggested format.
- Sample handwashing SOP.
- Suggested questions to answer, technical help and Food Code references for each required SOP. Michigan has adopted the 1999 FDA Model Food Code as law in Michigan.

Make copies as needed

Standard Operating Procedure

Establishment Name: _____

Subject:

What will be done and who will do it?

Who will make sure it's done and how?

How should problems be fixed?

What records will be kept?

Created (Date):

By:

Last Revised:

By:

Standard Operating Procedure
Joe's Coney Dogs
SAMPLE

Subject: Handwashing

What will be done and who will do it?

New employees must:

- Review this procedure.
- Watch the video "Effective Handwashing."
- Be trained by the team leader.
- Sign off on the new employee training checklist.

All employees must wash hands at labeled handsinks (2 in kitchen). DO NOT wash at dishwashing, food or mop sinks. Handwashing steps are as follows:

- Use water as hot as you can stand.
- Soap hands and lower forearms.
- Scrub for 20 seconds.
- Rinse.
- Dry with paper towel.

When must all employees wash hands?

- At beginning of shift.
- After using toilet.
- After coughing, sneezing, using tissue or handkerchief, eating, drinking or using tobacco.
- Between touching raw food and ready-to-eat food.
- Between glove changes.
- After handling dirty dishes.
- After touching hair or any body part except clean hands and arms.
- During food preparation as often as necessary to prevent cross-contamination.
- After doing other activities that contaminate the hands, such as handling trash or chemicals.

Who will make sure it's done and how?

- Team leaders are expected to continually model appropriate handwashing practices for employees.
- Team leaders shall monitor employee handwashing.
- Dishwashing staff are to assure that handwashing stations, including bathrooms, are supplied with soap and paper towels.
- Team leaders shall monitor handsinks at least once per shift to assure that sinks have the necessary supplies. The day team leader shall assure that necessary supplies are in stock.

How should problems be fixed?

- Team leaders must immediately train and counsel employees who improperly or inadequately wash hands or don't keep handsinks supplied.
- Team leaders must notify owner of any handwashing problems that can't be solved through training and counseling.

What records will be kept?

- Complete new employee training checksheet.

Created (Date): 6/15/04

By: Joe Dawton, Owner

Last Revised:

By:

For each standard operating procedure that may be required, questions to answer and technical information are listed.

Handwashing

Questions to answer

- What training will employees receive?
- What training will supervisors receive?
- What is the correct way to wash?
- When should employees wash?
- Where should employees wash or not wash?
- Who will keep sinks supplied with soap and paper towel?

Technical Help (See Food Code 2-301.12; 2-301.14; 2-301.15)

- All handsinks in bathrooms and kitchens must be labeled with a sign. Washing hands at dishwashing, mop or food sinks is not allowed.
- Handwashing steps are:
 - use water as hot as you can stand
 - soap hands and lower forearms,
 - scrub for 20 seconds,
 - rinse
 - dry with paper towel or hot air dryer.
- Hand sanitizers can be used after washing hands. Hand sanitizers may not be used to replace washing hands.
- All employees must wash hands:
 - at beginning of shift,
 - after using toilet,
 - after coughing, sneezing, using tissue, eating, drinking or using tobacco,
 - between touching raw food and ready-to-eat food,
 - between glove changes,
 - after handling dirty dishes,
 - after touching hair or any body part except clean hands and arms,
 - during food preparation as often as necessary to prevent cross-contamination,
 - after doing other activities that contaminate the hands, such as handling trash or chemicals.

Personal hygiene

Questions to answer

- What personal hygiene steps are needed before an employee comes to work?
- What clothes or uniforms must employees wear to work?
- What must an employee do if they have a cut or sore on their hands, arms or face?
- Where can employees drink, smoke or eat?
- What employee training will be done?

Technical Help (See Food Code subpart 2-201.11(B)(2); 2-302.11; 2-303.11; 2-304.11; 2-401)

- Outer clothing of food employees must be clean.
- Any cuts, burns, boils, skin infections or infected wounds on a food handler should be covered with a bandage. Cover bandages on hands with gloves. Food handlers with bandages may need to be assigned to jobs that do not involve food contact.
- Eating, drinking or using tobacco can only be done in certain areas away from food or equipment. Employees may drink in the food preparation area if the drink has a cover that does not have to be touched (a cover and a straw often work well).

Preventing bare hand contact with ready-to-eat food

Questions to answer

- What ready-to-eat foods are served?
- How will hand contact with ready-to-eat foods be avoided? For each food, should an employee use utensils, deli tissue, spatulas, tongs, single-use gloves, or dispensing equipment?
- Are different types of single-use gloves needed for employees that do different jobs? Are only vinyl gloves being used to eliminate allergic reactions from latex gloves?
- Is avoiding bare hand contact with some foods not feasible? If you answered yes, will ready-to-eat food be touched with bare hands under a written policy that complies with the MDA Food Law?
- What employee training will be done?

Technical Help (See Food Code 3-301.11 and 3-301.12)

- Ready-to-eat foods are foods that are edible without washing, cooking or additional preparation. These are foods that are expected to be eaten as they are. Foods reheated per individual order are considered ready-to-eat.
- Food handlers may not touch ready-to-eat foods with their bare hands. Food employees can touch raw fruits and vegetables to wash them before they are cut.
- Some ways to avoid touching ready-to-eat food include using utensils, deli tissue, spatulas, tongs, single-use gloves, or dispensing equipment.
- Suppliers make many different types of gloves. Some are loose and some are tight fitting. Some have powder and some are powder-free. Some employees may have or may develop allergies to latex gloves. Consult your glove supplier for assistance.
- Avoiding the handling of some ready-to-eat foods may not be possible. When food employees must touch ready-to-eat food, the establishment must first have a 10-point written plan that meets Michigan's Food Law, section 6151.

Employee Illness

Questions to answer

- What personal health information should be asked of applicants?
- What personal health information should be required from new hires and existing employees?
- How are employees trained to understand and report illness?
- When employees report illness, under what conditions should they be restricted from food handling or excluded from the establishment?
- When can restricted or excluded employees return to work handling food?
- When must the health department be notified about an ill employee?

Technical Help (See Food Code subpart 2-201)

- The person in charge must notify the local health department when a food employee is diagnosed with an illness due to any of the **BIG FOUR**: Salmonella Typhi (Typhoid Fever), Shigella (Shigellosis), Escherichia Coli O157:H7, or Hepatitis A virus.
- Employees must report if they have any of the **BIG FOUR**. This includes applicants once they have been made a conditional employment offer. Employees must report if they have diarrhea, fever, vomiting, jaundice, sore throat with fever, or lesions containing pus on an exposed body part. Employees must also report if they have been exposed to or are suspected of causing a confirmed outbreak, of any of the **BIG FOUR**. They must also report if: a. they live with a household member who has any of the **BIG FOUR** or b. if a household member works in or attends a setting where any of the **BIG FOUR** have caused a confirmed outbreak.
- The person in charge must exclude from the establishment employees diagnosed with any of the **BIG FOUR**.
- The person in charge must restrict or exclude employees with other symptoms. Restrict means the employee may not work with food, clean equipment, linens, etc. Read Food Code subpart 2-2 Employee Health for more information.
- The Food Code contains model forms in Annex 7, which an employer can use.
- Contact the local health department when there are questions about handling an ill employee.

Purchasing food from approved sources

Questions to answer

- What are the approved sources that food can come from?
- What are sources of food that are unacceptable?

Technical Help (See Food Code 3-201.11-17)

- Buy only from suppliers who are getting their products from licensed reputable purveyors and manufacturers who inspect goods and follow public health laws.
- Meat must be USDA inspected and/or graded.
- Home-prepared and home-canned food is not allowed.
- Wild mushrooms must be inspected.
- Uninspected wild game or wild caught fish is not allowed.

Cleaning and sanitizing food contact surfaces

Questions to answer

- What are the food contact surfaces in the establishment?
- What equipment must be cleaned in-place?
- How often do surfaces and clean-in-place equipment need cleaning and sanitizing?
- What chemicals will be used to clean and sanitize?
- What procedures will be used to clean and sanitize surfaces?
- What procedures will be used to clean and sanitize clean-in-place equipment?
- What employee training will be done?

Technical Help (See Food Code 1-201.10(9)(29); 4-501.114; 4-601.11; subparts 4-602&3; parts 4-7)

- Food contact surfaces are surfaces that food normally comes into contact with. Also, they are surfaces from which food may drain, drip or splash into food or onto a food contact surface.
- Cleaning is the removal of food, soil, and other types of debris from a surface. Detergents are cleaning agents that remove grease or fat associated with food residues. Cleaning does not, by itself, consistently reduce contamination to safe levels.
- Sanitizing is an additional step that can only occur after a surface is already clean. Sanitizing involves the use of heat or chemicals to reduce the number of microorganisms to safe levels.
- Procedures for cleaning and sanitizing equipment that cannot be immersed in a sink are often highly specific to the piece of equipment. Food Code and manufacturer specifications should be followed closely.
- Follow the manufacturer's label and Material Safety Data Sheet (MSDS) for cleaners and sanitizers used.
- Generally use a 3-step process on surfaces: 1. Wash, 2. Rinse, 3. Sanitize.

Cross-contamination prevention

Questions to answer

- What surfaces, pots, pans or utensils have both raw and ready-to-eat foods touch them?
- Do raw meats need special storage to prevent contamination of ready-to-eat foods?
- How do cooks taste foods during preparation?
- How will cutting boards be managed to prevent cross-contamination?
- How are fruits and vegetables cleaned and stored?
- How are in-use utensils stored?
- What employee training will be done?

Technical Help (See Food Code part 3-3)

Store and prepare foods to prevent contamination. Some methods of preventing cross-contamination include:

- A utensil may not be used more than once to taste food that will be served or sold.
- Use separate equipment for each type of food. Separate beef, fish, lamb, pork and poultry from each other unless intentionally mixing during preparation.
- Store food in package, covered container or wrappings.
- Clean visible soil from cans of food before opening.
- Properly manage cutting boards. Washing, rinsing and sanitizing cutting boards and food contact surfaces between preparing raw and ready-to-eat foods is required. An option is to use color-coded cutting boards to help prevent cross-contamination. For example, use red for meat, blue for fish, green for vegetables. When using a surface for the same food for many hours, clean and sanitize at least every four hours.
- Prepare raw and ready-to-eat foods at different times or in different areas.
- Separate washed fruits from unwashed fruits.
- Store food in this order in refrigerator.

Top shelf	Ready-to-eat-foods
	Fish
	Beef Roasts, Steaks
	Ham, Pork Chops, Eggs
	Ground Meat
Bottom shelf	Poultry

- Wash all fruit and vegetables thoroughly. Illnesses have been caused by contaminated produce. It may be impossible to remove bacteria from items such as sprouts and green onions. Consider not serving these raw.
- Wash melons and other fruits before cutting them. This prevents bacteria on the surface from being transferred to the fruit in the middle.
- In-use utensils can be stored: a. in the food, b. in a running water dipper well, c. on a clean surface, if the utensil and surface are cleaned and sanitized at least every four hours, d. in a container of hot water (at least 140°F). Container and utensils must be cleaned once every 24 hours.
- Don't let customers use soiled plates or silverware for refills at buffets.

Warewashing

Questions to answer

- What needs to be washed?
- How often do items need to be washed?
- Where does it need to be washed?
- What chemicals are used for washing and sanitizing?
- What are the set-up and washing procedures?
- What employee training will be done?

Technical Help (See Food Code parts 4-6 & 4-7)

- All pots, pans, utensils, silverware, plates, etc. need to be washed, rinsed and sanitized after being used.
- Employees need direction whether to wash items in a dishwashing sink or an automatic dishmachine.
- Dishwashing sinks require the following steps:
 - scrape food from dishes into disposal or garbage,
 - wash in hot soapy water,
 - rinse in clear hot water,
 - sanitize by soaking in a chemical sanitizing solution, and
 - air dry.
- An approved chemical sanitizer must be used. Approved chemical sanitizers contain either chlorine, iodine or quaternary ammonium. Follow manufacturer's instructions.
- Dishmachines must be operated per manufacturer's instructions. Dishmachine's sanitize using either a hot water or chemical spray during the final rinse.

Date-marking ready-to-eat, potentially hazardous food

Questions to answer

- What food requires date-marking?
- What date-marking system will be used?
- What employee training will be done?

Technical Help (See Food Code 3-501.17)

- Certain unpackaged foods must be clearly marked to indicate the date by which the foods must be consumed.
- This applies to foods that are potentially hazardous*, ready-to-eat and that will be held more than 24 hours.
- Potentially hazardous foods* that are reheated for immediate service also require date marking.
- Foods must be marked at the time of preparation, or in the case of a commercially processed food, at the time that the container or packaging is opened in a retail facility.
- Date marking is not the same as the "last date of sale"? A "last date of sale" is required for prepackaged perishable foods being offered for retail sale. Firms which package perishable foods must identify the product's suggested shelf life by use of a date based on both food safety and quality characteristics. "Last date of sale" requirements are spelled out in Section 8107 of the Michigan Food Law of 2000.
- Foods that **do not** require date marking are as follows:
 - foods that are not ready-to-eat (example: raw chicken).
 - foods that are not potentially hazardous (example: whole wheat bread).
 - whole, unsliced portions of cured and processed lunchmeat or other meat food products still remaining in the original cellulose casing after the casing is cut. Example: shelf stable salami
 - certain hard and semi soft cheeses identified by FDA that are not PHF (but may still require refrigeration). <http://vm.cfsan.fda.gov/~ear/ret-chdt.html>

Using time only (not time and temperature) as a method to control bacterial growth

Questions to answer

- What foods does your establishment plan to use time as the only control for bacterial growth?
- What are the specific procedures that will be used?
- What employee training will be done?

Technical Help (See Food Code 3-501.19)

- Time only, rather than time in conjunction with temperature, can be used as a public health control only for: a. working supplies of potentially hazardous food* before cooking, b. ready-to-eat potentially hazardous food that is displayed or held for service or immediate consumption.
- The food must be marked with the time that is 4 hours past the time it is removed from temperature control.
- The food must be served or discarded within the 4-hour limit. For example, a hamburger is cooked and wrapped at 11:00 am, then held at less than 140°F. The package must be marked 3:00 pm to show the time it must be sold or thrown away by.
- Time as a control may not be used when serving a highly susceptible population, such as hospital patients or children in day care.

Time and temperature control for thawing potentially hazardous food*

Questions to answer

- What foods does your establishment thaw?
- What are the specific thawing procedures that will be used?
- What employee training will be done?

Technical Help (See Food Code 3-501.12; 3-501.13)

- Approved thawing methods are: a. In the refrigerator, b. submerged under running water 70°F or below, and c. while cooking. When thawed in a microwave, food must immediately be placed in conventional cooking equipment.

Time and temperature control for cooking potentially hazardous food*

Questions to answer

- What foods or groups of foods must be cooked? For example, fish would be a group of foods.
- What is the minimum cooking temperature for each food or group of foods?
- How will temperature be checked?
- What employee training will be done?

Technical Help (See Food Code part 3-4)

Minimum internal cooking temperatures are:

165°F	Poultry, stuffing, stuffed meat or fish, casseroles, egg dishes, dishes combining raw and cooked food. Potentially hazardous food cooked in microwave.
155°F	Ground or flaked meats
145°F	Pork, beef and pork roasts, beef steaks, veal, lamb, commercially raised game animals, fish, foods containing fish, shell eggs for immediate service. See the Food Code, subpart 3-4 for alternate cooking times for beef and pork roasts and ground meat.
140°F	Fruits and vegetables that are cooked for hot holding.

Note: Cook to this temperature for at least 15 seconds

Time and temperature control for cooling potentially hazardous food*

Questions to answer

- What foods or groups of foods must be cooled? For example, gravies and soups would be groups of foods.
- What cooling procedures will be used for different foods or groups of foods?
- How will cooling times and temperatures be checked?
- What employee training will be done?

Technical Help (See Food Code 3-501.14-15)

- Cooked potentially hazardous food shall be cooled in two steps. Within 2 hours from 140°F to 70°F, then within 4 more hours from 70°F to 41°F.
- Food prepared from ingredients at room temperature shall be cooled to 41°F within 4 hours.
- Cooling methods include:
 - placing food in shallow pans.
 - separating food into smaller or thinner portions,
 - using rapid cooling equipment, (for example an ice paddle).
 - stirring the food in a container placed in an ice bath.
 - adding ice as an ingredient.
 - other effective means.
- Cover food loosely or leave uncovered to help cool food faster.
- Discard food that has not been cooled in the required time.
- Don't use equipment to cool foods unless the equipment has the ability to cool the food in the required times.

Time and temperature control for reheating potentially hazardous food*

Questions to answer

- What foods or groups of foods must be reheated?
- What reheating procedures and equipment will be used for different foods or groups of foods?
- How will reheating times and temperatures be checked?
- What employee training will be done?

Technical Help (See Food Code 3-403.11)

- When previously cooked food is reheated for hot holding, reheat to 165°F for 15 seconds within 2 hours.
- Properly cooked food reheated for immediate service, such as the roast beef for a sandwich, may be served at any temperature.
- Discard food that has not been reheated to 165°F in 2 hours.
- Don't use equipment to reheat if the food can't be reheated to 165°F in 2 hours.

Time and temperature control for hot holding potentially hazardous food*

Questions to answer

- What foods or groups of foods will be held hot?
- What hot holding equipment will be used for different foods or groups of foods?
- How will hot holding times and temperatures be checked?
- What employee training will be done?

Technical Help (See Food Code 3-501.16; 3-501.19)

- Use only hot holding equipment that can keep foods at 140°F or higher.
- Stir foods often.
- Keep foods covered.
- Take food temperatures at least every 2 hours.
- Discard foods after 4 hours if they have not been held at or above 140°F.

Time and temperature control for cold-holding potentially hazardous food*

Questions to answer

- What foods or groups of foods will be held cold?
- What cold-holding equipment will be used for different foods or groups of foods?
- How will cold-holding temperatures be checked?
- What employee training will be done?

Technical Help (See Food Code 3-501.16)

- Use only cold-holding equipment that can keep foods at 41°F or lower.
- Keep foods covered.
- Take food temperatures at least every 2 hours.
- Discard foods after 4 hours if they have not been held at 41°F or below.

Special transitory food units (SFTU's) only- Water Supply

Questions to answer

- Where will potable (drinkable) water be obtained from?
- How will the water connection be made?
- How will the individual fixtures or pieces of equipment be protected against backflow, backsiphonage or cross-connection?

Technical Help (See Food Code part 5-1; subpart 5-202; subpart 5-205; and part 5-3)

- An adequate supply of potable water must be available on-site for cooking and drinking purposes, and for cleaning and sanitizing equipment, utensils and food contact surfaces.
- Air breaks or air gaps in the waste drain lines is required for certain equipment. Certain water line connections must have the proper type of protective device. Your plan reviewer can help answer your questions on specific requirements.

Special transitory food units (SFTU's) only- Wastewater Disposal

Questions to answer

- How will you dispose of wastewater?

Technical Help (See Food Code part 5-4)

- Liquid wastewater (from sinks, ice machines, ice chests, mop water) must be properly disposed of using a sanitary sewer or approved holding tank. Wastewater cannot be dumped into storms drains, waterways or onto the ground.

***Which foods would be considered potentially hazardous?**

Microorganisms generally grow rapidly in moist, high protein foods that have not been acidified or otherwise further processed to prevent such growth. Examples of PHFs include, but are not limited to:

- Animal foods that are raw or heat treated such as:
 - Milk or milk products including cheese and whipped butter
 - Meats including raw or partially cooked bacon
 - Shell eggs
 - Fish
 - Poultry and poultry products
 - Shellfish
- Food derived from plants that are heat treated including:
 - Onions (cooked and rehydrated)
 - Cooked rice
 - Soy protein products (example:tofu)
 - Potatoes (baked or boiled)
- Food derived from plants that consist of:
 - Cut melons, or
 - Raw seed sprouts.
- Garlic-in-oil, and other vegetable-in-oil mixtures that are not treated to prevent the growth and toxin production of *C. botulinum*;
- Certain sauces, breads, and pastries containing potentially hazardous food (examples: meat, cheese, cooked vegetables or cream)

What is Not a PHF?

- An air-cooled hard boiled egg with shell intact;
- A food with water activity of 0.85 or less;
- A food with a pH of 4.6 or below when measured at 75°F;
- A food in a hermetically sealed container commercially processed to achieve and maintain sterility;
- A food for which laboratory evidence has demonstrated that rapid and progressive growth of pathogens or the slower growth of *C. botulinum* cannot occur.

Food establishment managers are responsible for accurately determining which of the foods they serve or sell are potentially hazardous and therefore require strict temperature control.

Assistance in determining if food meets these requirements is generally available from food industry consultants, independent consulting laboratories certified to conduct microbiological testing of foods, and university-based food scientists.

Part I/ Menu, Consumer Advisories & Food Flow

Worksheet Help		
Question #	Food Code & Food Law*	Guidance
2	Thawing FC 3-501.13	<ol style="list-style-type: none"> 1. Identify all <i>potentially hazardous foods</i> on the menu that must be thawed. 2. Check the thawing methods to be used for each food. <p>Note: Thinner foods (<1" thick) may consist of sliced meats, individual hamburger patties, hot dogs, some seafood, etc., Thicker foods (>1"thick) may consist of roasts, a case of hamburger patties, chicken, frozen pasteurized eggs, etc.</p>
3	Cooking Reheating FC 3-401.11-12 FC 3-403.10-11	<ol style="list-style-type: none"> 1. List the name of all cooking and reheating <i>equipment</i>. Include tabletop <i>equipment</i> such as rice cookers and microwaves. Steam tables should not be used for reheating and should be listed under #4. 2. Check whether each piece will be used for cooking and/or reheating, whether it is new or used, and whether it is listed by a third party testing organization such as the National Sanitation Foundation (NSF), ETL, etc. These firms test <i>equipment</i> to determine if recognized sanitation and construction standards are met.
4	Hot & Cold Holding FC 3-501.16	<ol style="list-style-type: none"> 1. List the name of all hot and cold holding <i>equipment</i>. Examples include: steam tables, electric hot boxes, insulated hot/cold boxes, salad bar units, refrigerators, etc. 2. Check whether each piece will be used for hot and/or cold holding, whether it is new or used, and whether it is listed by a third party testing organization such as the National Sanitation Foundation (NSF), ETL, etc. These firms test <i>equipment</i> to determine if recognized sanitation and construction standards are met. 3. Note any <i>equipment</i> listed under question 3 that will also be used for hot or cold holding.
5	Ice FC 3-202.16 FC 3-303.11-12	Describe in as much detail as possible how, when and where ice will be used to hold <i>potentially hazardous food</i> cold. Use of ice off-site for catering can be answered under question 9D.
6	Time as a Control FC 3-501.19	Under very specific and limited circumstances, time instead of temperature may be used to control bacterial growth. A careful reading of the relevant food code section is recommended before making a proposal. You must prepare and submit a standard operating procedure for each food item where time as a control is proposed.
7	Cooling FC 3-501.14-15	<ol style="list-style-type: none"> 1. Identify foods from the menu that will be cooled after cooking for later service. 2. Determine and list the cooling method(s) for each food.

8	Bare Hand Contact Washing Fruit/Veges Date Marking	FL 289.6151 FC 3-301.11 FC 3-302.15 FC 3-501.17	Unless a written alternative plan is developed and implemented, there can be no bare hand contact with <i>ready-to-eat</i> foods. List the methods you will use to avoid bare-hand contact.
9	Catering	Numerous	
<p>*FC = FDA 1999 Model Food Code. *FL = Michigan Food Law of 2000. To view the food code, food law and other fact sheets go to: http://www.michigan.gov/mda, keyword: MFLeduc, or call 517-373-1060 to request single free copies.</p>			

MENU

The menu is an integral part of the plan review process. The menu or a listing of all of the food and beverage items to be offered at the *food establishment* must be submitted by the applicant with the submission of all other plan review application documents. A facility, such as a school, that has a large rotating menu cycle, may provide a representative listing of the types of items served.

As with the inspection process, the plan review process focuses on the food and what will happen to the food. The source and quantity of food to be served will be reviewed along with the preparation and post-preparation operations and the proposed storage practices.

Food preparation processes will be evaluated to determine the types and volumes of foods to be prepared. Special attention is given to the review of complex food processes, which will involve:

- Multiple ingredients being assembled or mixed
- *Potentially hazardous foods*
- Foods that will be prepared or held for several hours prior to service
- Foods requiring cooling and reheating
- Multiple step processing (passing through the critical temperature zone, 140°F to 41°F more than once).

The style of food service will also be reviewed. The style of food service may be cook-to-order (cook-serve), self-service (buffet or salad bar), service of pre-packaged foods, service of large volumes of food, food preparation requiring multiple steps and handling, etc.

Menu evaluation involves the review of food sources, categories of foods and their required preparation, such as:

- *Approved* and inspected food source
- Thin meats such as poultry, fish, eggs, hamburgers, sliced meats, & fillets
- Thick meats and whole poultry (roast beef, whole turkey, whole chickens, & hams)
- Cold processed foods (salad, sandwiches, vegetables, etc.)
- Hot processed foods (soups, stews, casseroles, etc.)
- Bakery goods

This system is useful since the critical control points for each process remain the same regardless of the individual menu ingredients. The menu for a *food establishment* dictates the space and *equipment* requirements for the safe preparation and service of various food items. The menu will determine if the proposed receiving and delivery areas, storage area, preparation and handling areas, and thawing, cooking, and reheating areas are available and adequate to handle the types and volumes of foods being served. With a proper understanding of the menu, the plans for *food establishments* can be reviewed to assure that the food items proposed can be protected during the service operation.

Consumer Advisories

Consumer Advisories are required for food establishments serving undercooked raw animal products. View a guidance document at: www.michigan.gov/mda keyword: MFLeduc, or call your inspecting agency for a copy.

Food Flow

Why analyze flow?

The flow of food through a kitchen can greatly affect food safety. Contamination of *ready-to-eat* (RTE) foods can occur with poor food flow, such as when raw meat and seafood are prepared on the same table that is used to assemble sandwiches. Soil and bacteria from a dirty dish or seafood processing area can also be moved to other areas when employees must routinely enter these areas. Your plan reviewer needs to understand how the menu will be prepared in the *physical facilities* proposed.

Flow may be in a straight "assembly" line format or be organized to move food through departments that perform different functions. A well laid-out flow provides safer and more efficient food preparation. Mapping out your proposed flow may help you better identify problems with your layout.

What do I need to do?

You are being asked to be ready to discuss the flow of food from delivery through service. **Depending upon the complexity of your menu, your plan reviewer may schedule a consultation to discuss food flow with you.**

Use your floor plan layout to think through your food production processes.

- Determine the flow from the receiving door, through storage, preparation, cooking, assembly and hot holding, ending with the customer. Also think through how solid waste and soiled dishes and utensils will move through the facility. Be ready to discuss such items as:
 - Which sinks and preparation tables will be used for washing and prepping vegetables, meat and seafood?
 - What items will be stored in working refrigeration units?
 - Is there adequate separation between raw and *ready-to-eat* foods in storage and during preparation?
 - How will cooks and preparation staff avoid contaminating *ready-to-eat* foods with juices and bacteria from raw meats and seafood?
 - Do flow patterns change during different times of day?

How will this information be used in the review process?

A plan reviewer not only reviews whether the *physical facilities* comply with the food code, but also visualizes the number and types of food being prepared, along with how food and people will move through the facility. The reviewer can help you determine food code violations that will or may be created by the proposed layout.

In analyzing food flow, the plan reviewer will:

- Try to gain an understanding of how food, dishes and solid waste will move through the facility.
- Look for points where cross-contamination of bacteria from raw to *ready-to-eat* foods may occur.
- Determine where soiled dishes, solid waste, outside dirt or mop water may contaminate ice, food or preparation areas.

When areas of concern are found, one of the following may occur:

- A change will be required.
- A change will be recommended.
- A standard operating procedure (SOP) will be required to address how contamination will be avoided using the existing plan.
- You may be given an option of either making a plan change or developing a SOP.

Part 2/ Handwashing

The Centers for Disease Control has identified poor personal hygiene by food employees as a major cause of foodborne illness in the United States. Proper handwashing is a critical step in preventing bacterial and viral contamination of food. The number and placement of handsinks is a major focus of the plan review process. Giving careful thought to handsink locations can prepare your facility for enhanced food safety and prevent delays in the plan review process. Reading the following food code sections that relate to handwashing is highly recommended: 2-3, 5-202.12, 5-203.11, 5-204.11, 5-205.11, 6-301.11-20 and 6-501.18.

Each handwashing sink shall be provided with hot and cold water tempered by means of a mixing valve or a combination faucet to provide water at a temperature of at least 110°F. Any self-closing, slow-closing or metering faucet shall be designed to provide a flow of water for at least 15 seconds without the need to reactivate the faucet.

Handwashing sinks shall be of sufficient number and conveniently located for use by all employees in food preparation, food dispensing and utensil washing areas. Handwashing sinks shall be easily accessible and may not be used for purposes other than handwashing.

Splashguard protection is required if spacing to adjoining food, food preparation, food contact surfaces, and utensil washing area surfaces (drainboards) is within 18". Splashguards shall not hinder access to the lavatory, should extend from the front of the sink to 12" above the rim of the sink and be easily cleanable.

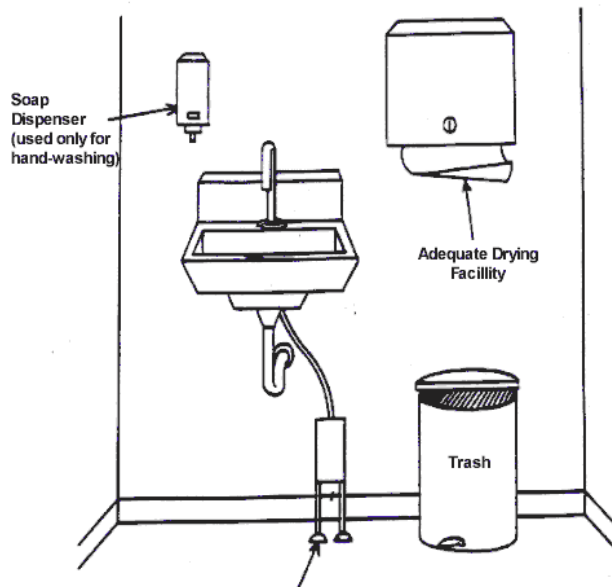

Handwash Sink Example

Provide a separate handwashing sink; disposable towels; supply of hand cleaning agent; and waste receptacle for each food preparation area, utensil washing area, and toilet room (required number based on law). Sinks used for food preparation or for washing *equipment* or utensils shall not be used for handwashing.

When locating handwashing sinks, follow these guides whenever possible:

- provide a sink close to each employee work station
- keep sinks within the employee's line of sight
- keep a handsink near the flow of food
- make sinks easily available for those handling both raw and *ready-to-eat* foods.

A sign or poster that notifies *food employees* to wash their hands shall be provided at all handwashing sinks used by *food employees* and shall be clearly visible to *food employees*.

Part 3/ Facilities to Maintain Product Temperature

Worksheet Help			
Question #		Food Code & Food Law*	Guidance
85	Refrigerated Storage	FC 3-501.14-16	Adequate refrigeration must be provided to cool and hold cold <i>potentially hazardous foods</i> at 41°F or less.
	Walk-in Refrigerator		<ol style="list-style-type: none"> List the number or name for each walk-in refrigerator and freezer. This should be the same number or name used on the plans. List the interior usable height of each walk-in. For example, for a unit with a 7' ceiling, the usable height would be 5.5' if the bottom shelf is 6" off the floor and storage will stop 1' from the ceiling. List the interior length and width of each unit.
	Upright Refrigerators		<ol style="list-style-type: none"> List the number or name for each upright or reach-in refrigerator and freezer unit that is provided for storage. Do not list working, preparation and line refrigerators. List the interior depth, width and height of each unit.
<p>*FC = FDA 1999 Model Food Code. *FL = Michigan Food Law of 2000. To view the food code, food law and other fact sheets go to: http://www.michigan.gov/mda, keyword: MFLeduc, or call 517-373-1060 to request single free copies.</p>			

Hot-holding and cold-holding facilities shall comply with the requirements of the FDA 1999 Food Code. Food *equipment* that is certified by an American National Standards Institute (ANSI)-accredited certification program (i.e. NSF, UL, ETL) will automatically be accepted as complying with the Food Code, provided *equipment* is in good condition and has not been altered or modified.

Refrigeration Facilities Sizing and Design

The plan review for storage needs to assure adequate refrigeration facilities for the proper storage, transportation, display, and service of *potentially hazardous foods*. Specific refrigeration needs will be based upon the menu, number of meals, frequency of delivery, and amount of preparation done in advance of service. All refrigerators must be capable of maintaining *potentially hazardous foods* (PHF) at 41°F or below.

If *potentially hazardous foods* are prepared a day or more in advance of service, a rapid cooling procedure capable of cooling *potentially hazardous foods* from 140°F to 41°F within 6 hours (140°F to 70°F in 2 hrs. & 70°F to 41°F in 4 hrs.) should be provided. The capacity of the rapid cooling facilities must be sufficient to accommodate the volume of food required to be cooled to 41°F within 6 hours.

Provide point-of-use refrigerators and freezers at workstations for operations requiring preparation and handling of *potentially hazardous foods*. Refrigeration units, unless designed for such use, should not be located directly adjacent to cooking *equipment* or other high heat producing *equipment* which may tax the cooling system's operation.

Calculating Total Refrigerated / Freezer Storage Needs.

To plan reserve storage, the following needs to be considered: menu, type of service, number of meals per day, number of deliveries per week and adequate air ventilation in the area where refrigeration system will be located. The following are suggested formulas to establish required reserve storage (note: only 40% of any walk-in unit actually provides usable space). The following formulas do not include space for storing *equipment* /utensils, cleaning supplies, maintenance supplies, promotional items, etc.

Formula 1 - Based on seating

This formula is simpler to calculate than formula 2, but has limitations. It should not be used for facilities with no seating, when a facility caters or whenever the seating is not representative of the volume of food served. It is also not suitable for facilities proposing reach-ins as storage units.

Total Interior Walk-In Storage Volume Needed:

Number of serving periods x number of seats x 0.5 x 1.25 (for establishments with drive-up facilities)

One serving period should be allotted for each of the following: breakfast, lunch, dinner, late night and 24- hour service.

Example:

Fast *food establishment*, open from 7:00 am to 11:00 pm (4 meal periods), 90 seats, drive-up window.

4 meal periods X 90 seats x 0.5 X 1.25 = 225 square feet

Formula 2- Based on meals served between deliveries

Total Interior Walk-In Storage Volume Needed:

$$\frac{\text{Vol. per meal (Cu. ft.)} \times \text{number of meals}}{.40}$$

Below are estimated typical meal volumes for each of three types of refrigerated storage:

Meat, Poultry and Seafood	=	.010-.030 Cu. ft. per meal
Dairy	=	.007-.015 Cu. ft. per meal
Vegetables and fruit	=	.020-.040 Cu. ft. per meal

Thus for a restaurant serving 1000 meals between deliveries (assume a minimum of 4 day storage) the following storage capacities are needed:

Meat refrigerated storage	=	$\frac{.030 \text{ Cu. ft./meal} \times 1000 \text{ meals}}{.40}$
	=	75 Cu. ft.
Vegetable refrigerated storage	=	$\frac{.040 \text{ Cu. ft./meal} \times 1000 \text{ meals}}{.40}$
	=	100 Cu. ft.
Dairy refrigerated storage	=	$\frac{.015 \text{ Cu. ft./meal} \times 1000 \text{ meals}}{.40}$
	=	37.5 Cu. ft.

To calculate the interior storage space (in square feet) required for the above example, divide the volume (Cu. ft), in each case, by the usable interior height of the unit. Example:

$$\begin{aligned} \text{For meat refrigerated storage} &= \frac{75 \text{ Cu. ft.}}{6 \text{ ft. (height)}} \\ &= 12.5 \text{ sq. ft.} \end{aligned}$$

Interior floor area would have to be 12.5 sq. ft. to accommodate refrigeration storage of meat for 1000 meals.

To estimate total interior volume or space, add together the requirements for each type of food.

To convert interior measurements to exterior floor area, multiply by 1.25. Thus, for meat storage, in the above example an exterior floor area = 1.25 x 12.5 sq. ft., or 15.6 sq. ft. would be needed.

Additional Recommendations for Refrigerated Storage Facilities

- Shelving for walk-in and reach-in refrigeration units should be *equipment* that is certified or classified for sanitation by an ANSI accredited certification program.

- Interior finishes of walk-in and reach-in refrigeration units should be certified or classified for sanitation by an ANSI accredited certification program.

- All refrigeration units must have numerically scaled indicating thermometers accurate to $\pm 3^\circ\text{F}$. The temperature-sensing device must be located in the unit to measure air temperature in the warmest part. All such thermometers should have an externally mounted indicator to facilitate easy reading of the temperature of the unit. Refrigerators and freezers shall be capable of maintaining appropriate temperatures when evaluated under test conditions of an ANSI accredited certification program.

- Air circulation within refrigeration and freezer units should not be obstructed and should allow for an even and consistent flow of cold air throughout the units.

- Refrigeration unit maximum operating temperature (cabinet air) should be:

Type	Max Temp	Max Compressor Operating Time
Storage & display refrigerators	Cabinet air temp. 41°F	70%
Refrigerated buffet units	Food temp. 33-41°F	
Storage & display freezer	Cabinet air temp. 0°F	80%
	Food frozen	

- Rapid pull down refrigeration units must be capable of cooling cooked PHF's from 140°F to 70°F within 2 hours, and from 70°F to 41°F within 4 hours or less.

- *Approved* covered juncture base around the interior and exterior.

- *Approved* enclosure between the top of the unit and the ceiling if this space is twenty-four inches or less. Fixed *equipment* shall be spaced to allow for cleaning along the sides and behind, or *sealed* to adjoining *equipment* or walls.

- Refrigeration units should not be installed exterior to the building if non-packaged foods will be transported from the unit to the *food establishment*.

- If the walk-in floors are water-flushed for cleaning or receive the discharge of liquid waste or excessive melt water, the floors should be non-absorbent (i.e. quarry tile or equal) with silicone or epoxy impregnated grout and sloped to drain. See part 12 for plumbing requirements for walk-in floor drains.

- Walk-in freezer doors should be equipped with pressure relief ports.

- All walk-in units should be constructed and installed in accordance with the 1999 FDA Food Code and/or code requirements and bear the certification mark of an ANSI accredited organization (e.g. NSF, UL, ETL).

- Each walk-in unit shall be equipped with lighting that provides 10 foot-candles of light throughout the unit when it is full of product.

Hot Holding and Reheating Facilities

The hot holding facilities must be capable of maintaining *potentially hazardous foods* at an internal temperature of 140°F or above during display, service and holding periods.

Reheating *equipment* must be capable of raising the internal temperature of *potentially hazardous foods* rapidly (within a maximum of 2 hours) to at least 165°F. Appropriate product thermometers will be required to monitor the food temperature.

Sample Cold Storage Calculations

Walk-In Refrigerator & Freezer Space Estimate					
Meals*	Interior cubic feet	Square feet of floor space, based on usable interior height			
		4' ceiling	5' ceiling	6' ceiling	7' ceiling
500	46-106	12-27	9-21	8-18	7-15
1000	93-213	23-53	19-43	15-35	13-30
1500	139-319	35-80	28-64	23-53	20-46
2000	185-425	46-106	37-85	31-71	26-61

*Number of meals served between deliveries

or

Storage Reach-In Refrigerator & Freezer Space Estimate**	
Meals*	Interior cubic feet
500	25-57
1000	50-113
1500	74-170
2000	99-227

*Number of meals served between deliveries

**Reach-in refrigerators and freezers only count toward the required refrigeration space if they are storage units. Working units for short-term storage at cook lines and preparation areas should not be included when calculating proposed storage.

Part 4/ Facilities To Protect Food

General Food Protection

Provide a separate food preparation area for handling, washing and preparing raw meat, fish, and poultry, if served. Where portable cutting boards are planned, they should be color coded or labeled for specific use.

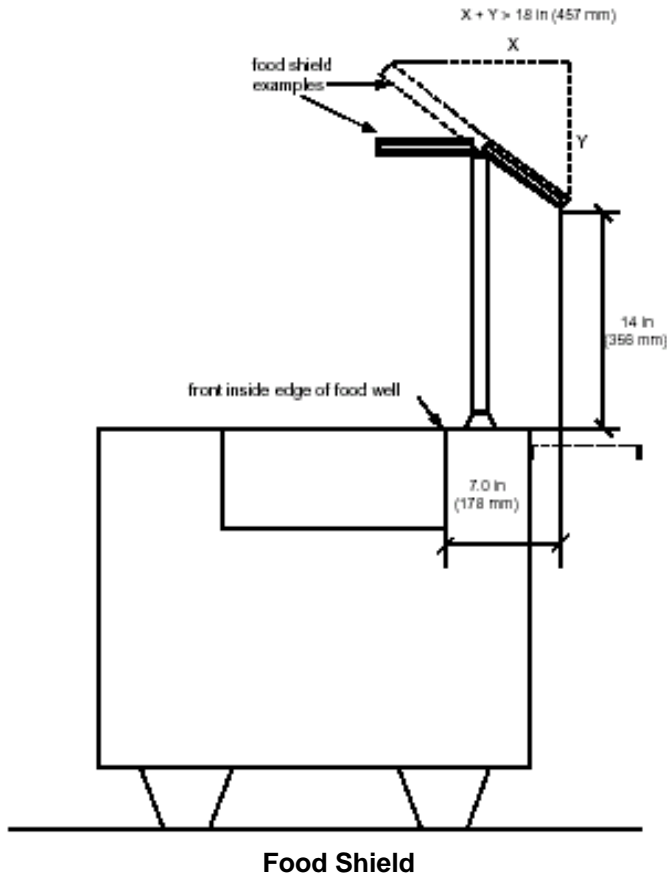

Salad bars and sneeze guards shall comply with the standards of an ANSI accredited certification program (i.e. NSF Standard 2).

Standard 2, in part, requires: "Food shields shall provide a barrier between the mouth of the customer and unpackaged food. The maximum vertical distance between a counter top and the bottom leading edge of a food shield shall be 14 in (356 mm). The bottom leading edge of the food shield shall extend a minimum horizontal distance of 7.0 in (175 mm) beyond the front inside edge of a food well. The sum of a food shield's protected horizontal plane (X) and its protected vertical plane (Y) shall equal a minimum of 18 in (450mm). Either X or Y may equal 0. Food shields shall be transparent and designed to minimize obstruction of the customer's view of the food. To protect against chipping, exposed edges of glass shall be protected by tight fitting channels, stripping materials, or other means such as rounding the edges of tempered glass."

From NSF/ANSI Standard 2. Used with permission of NSF.

When patrons have access to ends of units, the same shielding requirements apply.

All food being displayed, served, or held must be adequately protected from contamination by the use of: packaging; serving line, storage or salad bar protector devices; display cases; or by other effective means, including dispensers.

Adequate facilities must be provided to promote good hygienic practices, sanitary food handling and to minimize the potential of cross-contamination between *ready-to-eat* and raw products.

Running water dipping wells should be provided for the in-use storage of dispensing utensils where frozen desserts are being portioned and dispensed.

Clean *equipment* and utensils shall be stored in a clean, dry location where they are not exposed to splash, dust, or other contamination. This should be of particular concern at salad bars and waitress stations.

Part 5/ Water Supply, Sewage Disposal & Grease Traps

Worksheet Help			
Question #		Food Code & Food Law*	Guidance
32-33	Water Supply	FC 5-1	See information below.
34-35	Sewage Disposal	FC 5-403.11	See information below.
*FC = FDA 1999 Model Food Code. *FL = Michigan Food Law of 2000. To view the food code, food law and other fact sheets go to: http://www.michigan.gov/mda , keyword: MFLeduc, or call 517-373-1060 to request single free copies.			

Enough potable water for the needs of the *food service establishment* must be provided from a source constructed and operated according to law. Potable water from a municipal water supply is preferred when available. A municipal water supply is considered a type I public water supply. The oversight responsibility for these supplies is under the jurisdiction of Michigan Department of Environmental Quality (MDEQ). Other food service operations operate their water supplies from wells. These are considered non-community type II public water supplies. These are also regulated under the authority of MDEQ, with the exception that local health departments survey and monitor these supplies for potential contamination.

Establishments using an on-site water supply are regulated as described in the following:

Noncommunity Public Water Supply Owner's Guide

In 1974, out of concern for the quality of the water that we drink, Congress passed the Safe Drinking Water Act. This Act gave the U.S. Environmental Protection Agency (EPA) responsibility for establishing and enforcing drinking water quality standards nationwide. The Michigan Safe Drinking Water Act (Act 399) was enacted in 1976 and enables the Michigan Department of Environmental Quality to maintain primacy (state authority) over the drinking water program in our state. Local health departments are under contract with the Department of Environmental Quality to maintain local noncommunity programs for the public water supplies of Michigan. The following information focuses on Noncommunity Public Water Systems (PWS) at *food establishments*.

Definitions

A Noncommunity Public Water Supply (PWS) is defined as "a system that serves any nonresidential facility that provides water for drinking or domestic purposes to 25 or more persons at least 60 days out of the year, or has 15 or more service connections." A Noncommunity PWS may be further broken down into two categories dependent on the use of the systems.

- Transient: a transient PWS is a supply that serves 25 or more **different** people a day at least 60 days of the year (or 15 or more service connections). Restaurants are considered to be transient water supplies.
- Nontransient: a nontransient PWS is a supply that serves the **same 25** or more people at least 180 days of the year. Examples would include schools, industries, child care centers and office buildings

Responsibilities of a Noncommunity Public Water Supply Owner

- Maintain and operate water systems in a safe and sanitary condition.
- Collect water samples to assess compliance with drinking water standards.
- Notify the public in cases of noncompliance with standards or sampling requirements.
- Obtain permits for construction or alteration of water well systems.

- Maintain records for noncommunity water systems including sample results and correspondence with health departments.
- Submit payment for water samples and annual fees.

Sanitary Survey

A comprehensive inspection of the well and water distribution system is required every five years. This assesses the potential for contamination to enter the water system. Appropriate sampling frequencies are assigned. Water system deficiencies may increase the likelihood of contamination and are required to be fixed. Water systems with a satisfactory inspection and sampling history can be assigned minimum sampling.

Routine Sampling Requirements

Transient Supply

- Coliform bacteria - One sample required every three months unless reduced to once yearly, based on satisfactory survey and sampling history.
- Nitrate - One sample per year.

Nontransient Supply

- Coliform bacteria. One sample every three months unless reduced to once a year based on a satisfactory survey and sampling history.
- Nitrate. One sample per year.
- Chemical: Metals, Volatile Organic Chemicals, Synthetic Organic Chemicals, Cyanide, and Lead and Copper.
- Sample frequencies vary. Contact your local health department for your chemical sampling frequency.

Permits

A construction permit is required prior to drilling or altering a noncommunity well. The permit is intended to assure adequate well location with respect to isolation distance from sources of contamination, proper construction methods and materials, and design criteria. Applications are obtained from your county health department.

Record Keeping

Noncommunity water systems are identified by a seven-digit water supply serial number or WSSN. To insure proper identification this number must be used with all correspondence and sample data submitted to the county health department and laboratories.

Annual Fees

Annual fees are charged owners of all noncommunity water systems. These funds are collected by the Department of Environmental Quality and distributed to county health departments in order to support services provided to noncommunity facilities.

How Does This Benefit My Facility?

- The fees allow the Department of Environmental Quality to maintain a state run program as opposed to direct federal administration.
- It allows more flexibility, including significant reductions in sampling that would not be available in a federal program.
- It results in a program that better serves public water system owners and the people of Michigan.

For More Information

The environmental health staff at county/district health departments provides direct services to public water supplies in their jurisdictions. Questions regarding owner's responsibilities should be directed to your local health department. Noncommunity program staff may be reached at the Drinking Water and Radiological Protection Division in Lansing at 517-241-1370. Upper Peninsula inquiries may be directed to 906-475-2045.

The Type II Noncommunity Water Supply web site address is: www.michigan.gov/deq, Programs: Non-Community Water Supply

Sewage Disposal

All *sewage*, including liquid waste, shall be disposed of by a public *sewage* system, or by an on-site *sewage* disposal system constructed and operated according to law.

When greater than 10,000 gallons per day of wastewater will be discharged to the ground or surface water, a Michigan *food establishment* must obtain plan approval, plus a permit, from the appropriate division of the Michigan Department of Environmental Quality. For discharges of this volume, *sewage* treatment other than a septic tank and subsurface disposal system are usually necessary.

When less than 10,000 gallons per day of wastewater will be discharged to the ground, a Michigan *food establishment* uses the Food Service Design Criteria (quoted in the section directly below) and found in the publication "Michigan Criteria for Subsurface *Sewage* Disposal" April 1994, distributed by the Michigan Department of Environmental Quality. Local health departments are typically responsible for issuing permits for on-site *sewage* systems serving *food establishments*, utilizing the referenced criteria. The requirements may change at any time. Please contact the local health department in the jurisdiction where the establishment will be built to determine current design criteria and permit application requirements. Increasingly, alternative types of *sewage* systems, other than the traditional septic tank system, are being used. You may wish to discuss alternative system options with your local health department.

Food Service Design Criteria

Review and evaluation of *sewage* systems serving restaurants has determined that utilization of septic tank tile-field systems at restaurants requires a much more conservative approach to site evaluation, design, and construction, if success is to be achieved. As a result of our investigations, we have come to the following conclusions concerning these installations:

- Soils suitability for installation of an on-site *sewage* disposal system serving a food service establishment is much more critical. In normal situations soil textures such as fine sand, loam, and sandy clay loam, are acceptable for utilization of on-site *sewage* systems under these criteria. However, for *food establishments*, experience shows that only coarse sand, medium sand, loamy sand and sandy loam are the types of soil to use if success is to be achieved.
- The maximum acceptable application rate for design of *sewage* systems serving *food service establishments* is critical, if success is to be achieved. Where as in normal situations, application rates as high as 1.0 gallons per square foot per day are allowable, experience dictate application rates of .25 gallons per square foot per day are warranted when designing systems for *food service establishments*.
- Experience has shown that even with additional precautions, design and construction system failure is more frequent when *sewage* systems serve *food service establishments*. Accordingly, provisions to provide more reserve area is warranted when new *food service establishments* are proposed.

In view of the aforementioned comments, *sewage* systems serving restaurants shall follow the following design criteria:

- The application rate used to design the *sewage* system shall conform to the following table:

Soil Texture and Structure	Permeability		Maximum Acceptable Application Rate GPD/ft ²	
	In/Hr	Min/Inch	Trench	Bed
Coarse Sand Medium Sand	6 or more	Less than 10	.5	.5
Loamy Sand	3-6	10-20	.33	Not Acceptable
Sandy Loam	2-6	10-30	.25	Not Acceptable

- Only sites with sufficient area containing suitable soils to install an initial system and one replacement system shall be *Approved*.

- Design flows for restaurants shall be calculated using the following formula:

Design Flow = No. seats x No. seat turnovers x gallons per seat.

Gallons Per Seat = 5-10 gallons, based on the type of facility (fast food versus full-service restaurant), type of *equipment* (paper service, versus dishes) and hours of operation.

Seat Turnover = A number based on the estimate of the type of business after discussion with restaurant owner and design consultant, consideration of restaurant location, and consideration of type of business.

Example 1: A full-service restaurant, located near a large retail mall, with 9 seat turnovers per day and 100 seats.

100 seats x 9 seat turnovers x 10 gallons/seat = 9,000 gallons

Example 2: A fast food restaurant with 100 seats and 5 seat turnovers each day.

seats x 5 seat turnovers x 5 gpd = 2,500 gallons per day

- Trench systems are preferred over bed systems.

- Septic tanks shall be designed to provide a minimum of 72 hours retention. Either multiple tanks or a multiple compartment tank shall be used. The first tank or compartment shall have a minimum capacity of approximately 2/3 the total volume. Alternatively, separate plumbing with a grease interception device for kitchen waste may be installed and septic tank capacity reduced to 24- hour retention time for a total wastewater flow. Grease interception devices shall be designed in accordance with the Environmental Protection Agency design manual on on-site *sewage* treatment and disposal.

Example 1: A full service restaurant generating a daily flow of 9,000 gallons per day without installation of a grease trap. An 18,000 gallon septic tank followed by a 9,000 gallon septic tank.

Example 2: A full service restaurant generating a daily flow of 9,000 gallons per day with a grease interception device installed on the kitchen waste line.

•A 6,000 gallon septic tank followed by a 3,000 gallon septic tank with a 14,000 gallon grease interception device installed on the waste line. Grease interception device calculated as per formula on page 323 of Environmental Protection Agency “Design Manual on On-Site Wastewater Treatment and Disposal Systems”.

Grease Traps

The food code requires that grease traps, if used, be located to be easily accessible for cleaning. The two traditional configurations for a grease trap are:

- Locate a smaller grease trap inside the building to serve specific pieces of major grease producing *equipment* (i.e. three compartment sink).
- Locate a larger grease trap outside the building to collect grease from all kitchen grease producing *equipment*.

Michigan Plumbing Code

Grease traps are required for new *food establishments* in Michigan if there are grease-laden wastes. The code requires that the grease-retention capacity in pounds should equal at least twice the flow capacity in gallons per minute. The Michigan Plumbing Code adopts the requirements of the 2000 International Plumbing Code (IPC). Contact your state or local plumbing inspector regarding the applicability of these requirements to a specific project.

Michigan Criteria for Subsurface Sewage Disposal

The Michigan Criteria for Subsurface *Sewage Disposal*, April 1994 require that, if used, a grease trap be constructed in accordance with Environmental Protection Agency “Design Manual on On-Site Wastewater Treatment and Disposal Systems”. This manual discusses only the sizing of large outdoor-type grease traps and mirrors the plumbing code’s sizing requirements. An excerpt from the manual states:

8.2.4 Design

Sizing of grease traps is based on wastewater flow and can be calculated from the number and kind of sinks and fixtures discharging to the trap. In addition, a grease trap should be rated on its grease retention capacity, which is the amount of grease (in pounds) that the trap can hold before its average efficiency drops below 90%. Current practice is that grease- retention capacity in pounds should equal at least twice the flow capacity in gallons per minute. In other words, a trap rated at 20 gpm (1.3 l/sec) should retain at least 90% of the grease discharged to it until it holds at least 40 lb. (18kg) of grease. Most manufacturers of commercial traps rate their products in accordance with this procedure. More detail and additional formulas may be found in the EPA manual.

Note: The Michigan Department of Environmental Quality warns that research shows grease traps are only minimally effective in reducing the fats, oils and grease discharged to subsurface disposal systems. To effectively reduce high organic strength fats, oils and grease and prolong life expectancy of subsurface systems, aerobic pretreatment may be considered. Pretreatment, when properly designed, constructed, operated and maintained has been proven an effective means to extend life expectancy.

FDA Water Use Data Guide - may be used in the absence of other formulas or information

	Gallons Per Day		Gallons Per Day
3 compartment sink:		Prep sink:	
49 gals. x # fills / day =	##	15 gallons. X # fills / day =	##
Floor wash: Mop bucket size		Full time employees	
(gallons) x # fills / day =	##	# x 30 gals. each =	##
		Dishmachine	
General sanitation =	30	Gal/hour rating x	##
		# meal periods =	
		Total Daily Usage =	###

Part 6/ Equipment And Installation

All *equipment* in *food establishments* should be certified or classified for sanitation by an ANSI accredited certification program.

Equipment including ice makers and ice storage *equipment* shall not be located under exposed or unprotected sewer lines, open stairwells or other sources of contamination.

The following *equipment* installation requirements will help to ensure proper spacing and sealing which will allow for adequate and easy cleaning:

Floor Mounted Equipment

Whenever possible *equipment* should be mounted on *approved* castors or wheels to facilitate easy moving, cleaning, and flexibility of operation. Wheeled *equipment* requiring utility services should be provided with easily accessible quick-disconnects or the utility service lines should be flexible and of sufficient length to permit moving the *equipment* for cleaning. Check with local fire safety and building codes to ensure that such installations are acceptable.

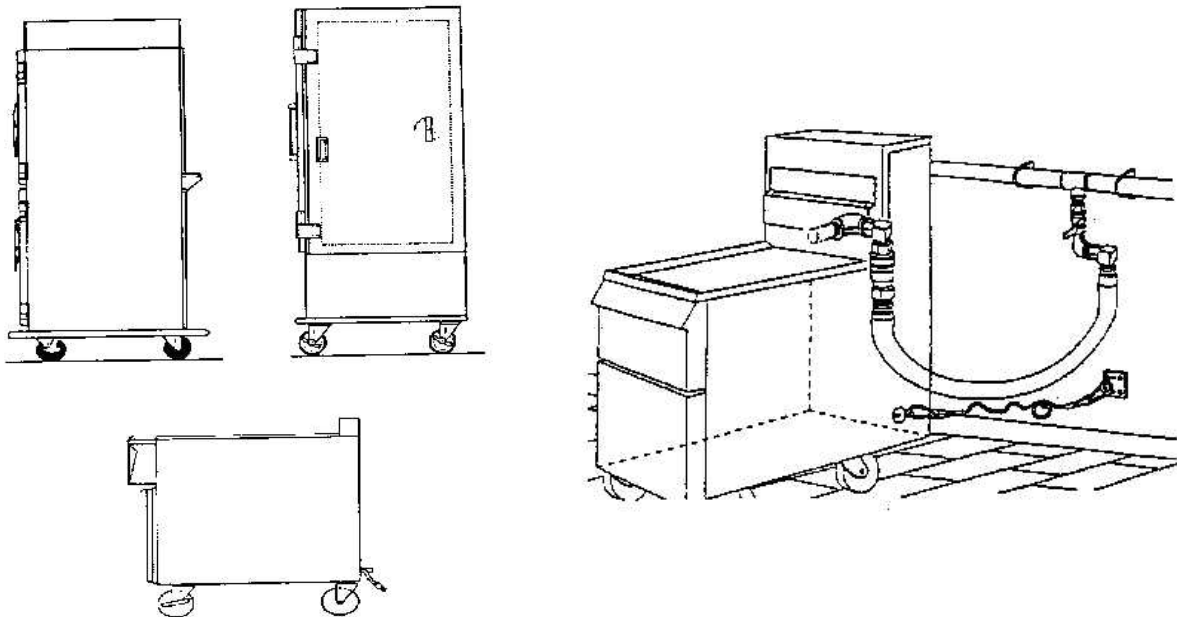

Kitchen Equipment Mounted on Castors

Flexible Gas Connector with Keeper Chain

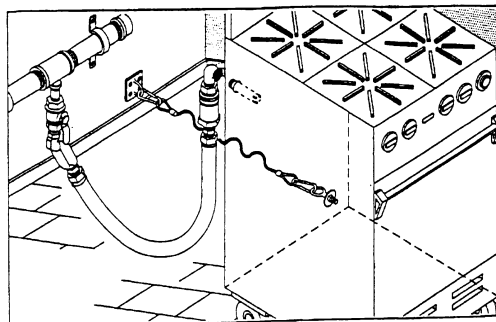

Floor-mounted *equipment* not mounted on wheels or castors with the above utility connections should be:

- *Sealed* to the floor around the entire perimeter of the *equipment* (the sealing compound should be pliable but not gummy or sticky, non-shrinking, retain elasticity and provide a water and vermin-tight point); or
- Installed on a solid, *smooth*, non-absorbent masonry base. Masonry bases and curbs should have a minimum height of 2" and be covered at the junction of the platform and the floor with at least a 1/4" radius. The *equipment* should overhang the base by at least 1" but not more than 4". Spaces between the masonry base and the *equipment* must be *sealed*; or
- Elevated on legs to provide at least a 6" clearance between the floor and *equipment*. The legs shall contain no hollow open ends.
- Display shelving and refrigeration units, and display freezers may be exempt from the above.

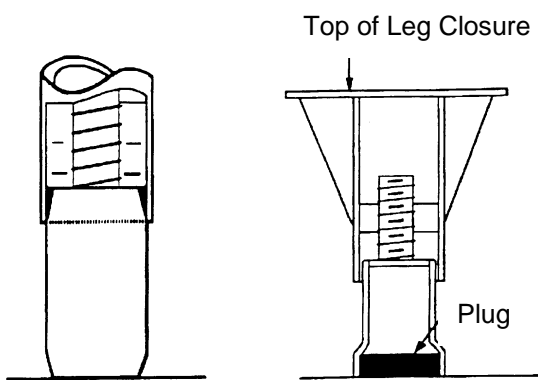

For *equipment* not readily moveable by one person, spacing between and behind *equipment* must be sufficient to permit cleaning. Provide at least 6" of clear unobstructed space under each piece of *equipment*.

If all the *equipment* butts against a wall it must be joined to it and/or *sealed* in a manner to prevent liquid waste, dust and debris from collecting between the wall and the *equipment*.

When *equipment* is butted together or spreader plates are used the resultant joint must prevent the accumulation of spillage and debris therein and must facilitate cleaning.

Provide unobstructed and functional aisle and working spaces between units of *equipment*. A minimum 36" width is recommended.

All utility and service lines and openings through the floor must be *sealed* adequately. Exposed vertical and horizontal pipes and lines must be kept to a minimum. The installation of exposed horizontal utility lines and pipes on the floor is prohibited. Any insulation materials used on utility pipes or lines in the food preparation or dishwashing areas must be *smooth*, non-absorbent and easy to clean. It is desirable that switch boxes, electrical control panels, wall mounted cabinets, etc. be installed out of the cooking and dishwashing areas. Electrical units, which are installed in areas subject to splash from necessary cleaning operations or food preparation, should be watertight and washable.

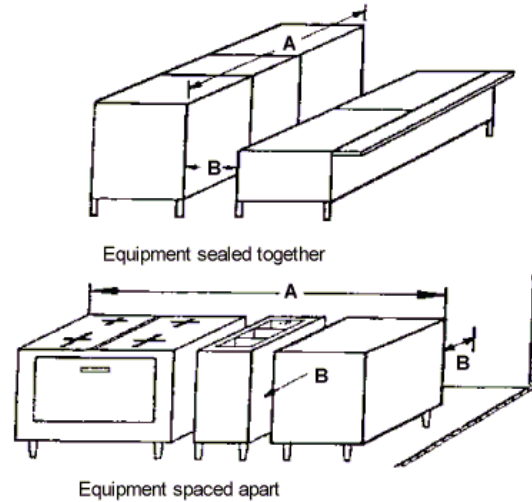

Recommended Equipment Spacing From Walls, Provided Access is Available From Both Ends:

<u>Equipment Length (A)</u>	<u>Space From Walls and Equipment (B)</u>
4' or less	6"
4' - 8'	12"
8' or more	18"

Equipment Spacing

Table Mounted Equipment

All table mounted *equipment* shall be:

- Sealed to the table or counter; or
- Elevated on *approved* legs to provide at least a 4" clearance between the table or counter and *equipment* and installed to facilitate cleaning; or
- Easily moveable/ *portable*

Equipment open underneath, such as drain boards, dish tables, and other tables should be installed 4" away from the wall or *sealed* to the wall. Metal legs of all tables and sinks in food preparation areas should be made of stainless steel. The undershelves of food preparation tables should also be made of stainless steel.

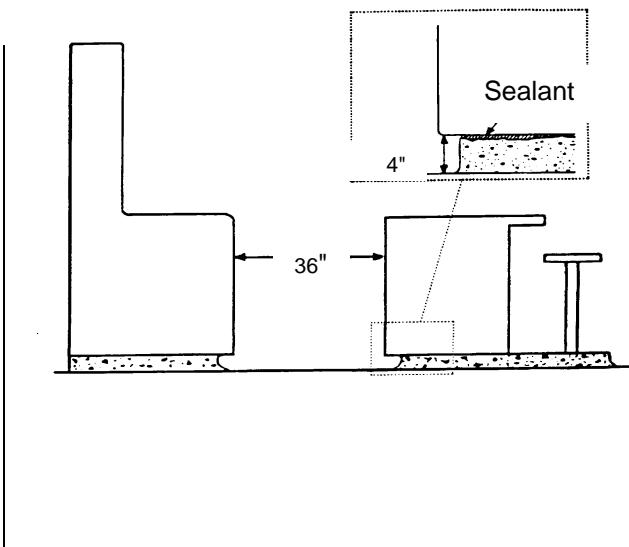

Part 7/ Dry Storage

Worksheet Help			
Question #		Food Code & Food Law*	Guidance
86	Dry Storage	FC 3-305.11-12	Some establishments have separate rooms for storage of dry food and single-service items, while others use shelving within the main preparation area. If separate rooms are proposed for storage, list the room dimensions requested. If various shelving units are proposed, but there is no separate storage room, list the dimensions of shelving proposed. For example: 12' of 1.5' wide x 6' high shelving and 18' of 2' wide x 4' high shelving. Note: Do not list shelving for toxic items and clean utensils. If a portion of a store room will be used for these items, please note the amount of the room set aside for this use.
<p>*FC = FDA 1999 Model Food Code. *FL = Michigan Food Law of 2000. To view the food code, food law and other fact sheets go to: http://www.michigan.gov/mda, keyword: MFLeduc, or call 517-373-1060 to request single free copies.</p>			

The dry storage space required depends upon the menu, number of meals, quantities purchased, and frequency of delivery. The location of the storeroom should be adjacent to the food preparation area and convenient to receiving. Adequate ventilation should be provided. Ideally, the storeroom should be free of uninsulated steam and water pipes, water heaters, transformers, refrigeration condensing units, steam generators or other heat producing *equipment*. Temperatures of 50°F to 70°F are recommended.

Suggested formulas for estimating required storage space are:

Formula #1: Based on seating

Storage Area (ft²) = 0.5 ft² X # seats X # meal periods X 1.25 (for establishments with drive-up facilities)

Example: Assume a restaurant with 80 seats that serves 3 meal periods (breakfast, lunch and dinner).

Required storage area = 0.5 X 80 X 3 = 120 ft² store room

120 ft² store room x 30% usable space = 120 x 0.3 = 36 ft² of full height shelving in the store room

Formula #2: Based on meals served between deliveries

$$\text{Storage Area (ft}^2\text{)} = \frac{\text{Volume per meal} \times \text{Number of meals between deliveries}}{\text{Average height} \times \text{Fraction of usable storeroom floor area}}$$

- Volume per meal = 0.025 to 0.075 cu. ft. per meal served
- Useful storeroom height = 4 to 7 feet
- Storage time between deliveries = 3 to 14 days
- Fraction of useable storeroom floor area = 0.03 to 0.6

Example: Assume 100 meals per day and a 10 day storage between deliveries = 1000 meals for which to provide storage:

$$\text{Required Storage Area} = \frac{0.075 \text{ cubic feet} \times 1000 \text{ meals}}{5 \text{ feet} \times 0.3} = 50 \text{ ft.}^2 \text{ store room}$$

50 ft² of store room x 30% usable floor space = 50 x 0.3 = 15 ft² of full height shelving in the store room

Shelving can be constructed of suitably finished hard wood, durable plastic or preferably of corrosion resistant metal. The highest shelf for practical use is 7' and the lowest one should be 6" from the floor. Clearance between the shelves should be at least 15". Sufficient moveable dunnage racks and dollies (with *smooth* surfaces, cleanable in case of food spillage or package breakage) should be provided to store all food containers at least 6" above the floor.

Dunnage racks, pallets, etc. should be spaced sufficiently from walls to allow for vermin monitoring and inspection. A space of 18" is recommended. Wooden shelving requires a higher level of maintenance and is more conducive to vermin infestation. Food containers shall not be stored under exposed or unprotected sewer lines or leaking water lines. *Approved* food containers with tight-fitting covers and dollies should be used for storing bulk foods such as flour, cornmeal, sugar, dried beans, rice and similar foods. Scoops are needed for each food storage container in use.

Meals & storage room Dry storage space need estimate (Calculated at 0.30 usable storeroom floor area)				
Meals*	Square feet of <u>store room</u> (based on usable room height)			
	4' usable height	5' usable height	6' usable height	7' usable height
500	10-31	8-25	7-21	6-18
1000	21-63	17-50	14-42	12-36
1500	31-94	25-75	21-63	18-54
2000	42-135	33-100	28-83	24-71
*Number of meals served between deliveries				

or

Meals & shelving with no storage room Dry storage space need estimate				
Meals*	Square feet of <u>shelving</u> (based on usable room height)			
	4' usable height	5' usable height	6' usable height	7' usable height
500	3-9	3-8	2-6	2-5
1000	6-19	5-15	4-13	4-11
1500	9-28	8-23	6-19	5-16
2000	13-38	10-30	8-25	7-21
*Number of meals served between deliveries				

or

The following charts are based on seating and are not applicable if an establishment caters, has no seating, has take-out or a drive-through window. Breakfast, lunch, dinner, service after 9:00 p.m. and 24-hour service each count as one meal period.

Seating & storage room Dry storage space estimate Square feet of <u>storage room based on seating</u>				
Number of seats	Number of meal periods (B=1, L=1, D=1, >9pm=1, open 24 hr.)			
	1	2	3	4
50	42-83	83-167	125-250	167-333
100	83-167	167-333	250-500	333-667
150	125-250	250-500	375-750	500-1000
200	167-333	333-667	500-1000	667-1,333

OR

Seating & shelving with no storage room Dry storage space estimate Square feet of <u>shelving based on seating</u>				
Number of Seats	Number of meal periods (B=1, L=1, D=1, >9pm=1, open 24 hr.)			
	1	2	3	4
50	25	50	75	100
100	50	100	150	200
150	75	150	225	300
200	100	200	300	400

Part 8/ Sinks & Warewashing Facilities

Worksheet Help			
Question #		Food Code & Food Law*	Guidance
10	Dishwashing	FC 4-5 through 4-7	See information below
*FC = FDA 1999 Model Food Code. *FL = Michigan Food Law of 2000. To view the food code, food law and other fact sheets go to: http://www.michigan.gov/mda , keyword: MFLeduc, or call 517-373-1060 to request single free copies.			

Sinks

Be sure to check your plans to be sure you have included all of the following types of sinks:

- Handsinks (see part 2)
- Mop sink(s)
- Food preparation sink(s)
- Warewashing sink(s)

Food Preparation Sink

Provide separate areas to segregate food handling operations involving raw and ready- to-eat products. For washing raw fruits and vegetables, it is advisable to provide a separate food preparation sink with a minimum 18" drainboard.

Utility Facility

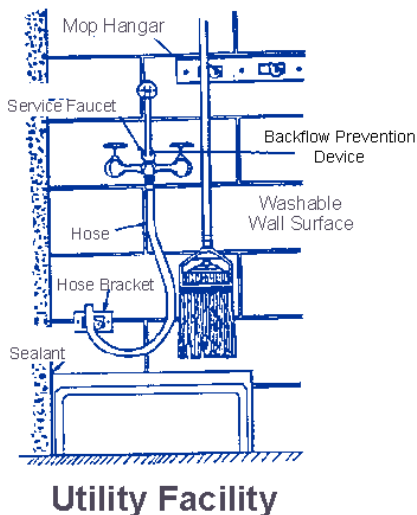

At least one utility sink or curbed cleaning facility with a floor drain shall be provided for cleaning mops or disposal of liquid wastes. The water supply must be protected against *backsiphonage* (see part 12). A properly sized mop and broom rack shall be provided. All toxic materials including cleaning compounds, pesticides, sanitizers, etc. must be stored in an area away from food preparation.

Manual Warewashing

For manual washing and sanitizing of utensils, provide a stainless steel sink with no fewer than 3 compartments. The sink compartments shall be large enough to hold the largest pot, pan or piece of *equipment*. Each compartment shall be supplied with adequate hot and cold potable running water. Integral drainboards of adequate size shall be provided on both sides of the sink for cleaned and soiled utensils. When *approved*, 2 compartment sinks may be allowable under certain conditions.

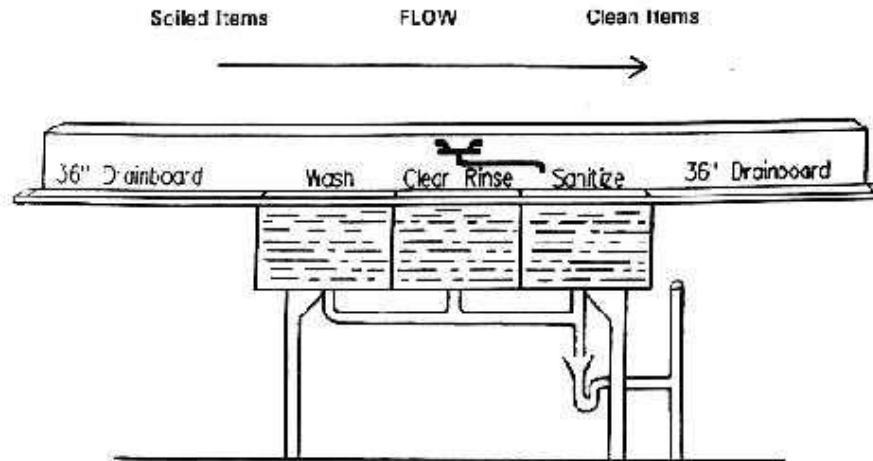

Recommended warewashing arrangement using three-compartment sink. Drainboards for soiled dishes and for cleaned utensils must be adequate. A 36" drainboard should have a pitch of $\frac{1}{8}$ " to $\frac{3}{4}$ " per foot toward the sink.

Three Compartment Sink With Indirect Waste

Drainboards, utensil racks, or tables large enough to accommodate all soiled and cleaned items that may accumulate during hours of operation shall be provided for necessary utensil holding before cleaning and after sanitizing.

Locate a floor drain in the immediate vicinity of the sink in areas where wet pots, utensils and *equipment* are air-drying. *Approved* racks, shelves or dish tables are to be provided adjacent to the warewash sink.

Provide adequate facilities for preflushing or prescrapping *equipment* and utensils.

An *approved* chemical test kit for determining sanitizer strength shall be available and used.

Working supplies of cleaners and sanitizers must be stored in an *approved* location. A recommended storage location is on a wire shelf below the drainboard of the 3 compartment sink.

Mechanical Warewashing

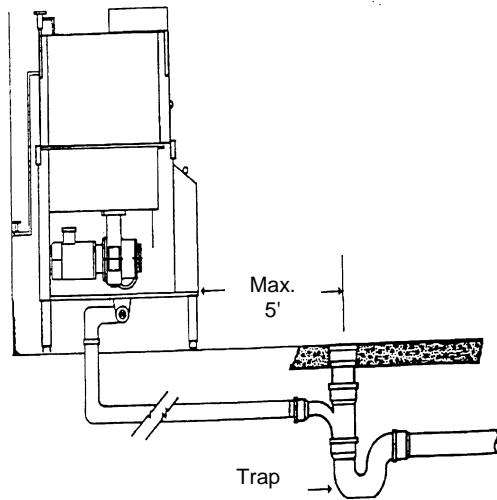

Warewashing Machine with a Direct Waste Connection

The waste line for all mechanical warewashing machines must not be directly connected to the sewer line. Except that the waste line may be connected directly on the inlet side of a properly vented floor drain when the floor drain is within 5' of the warewashing machine and the drain line from the machine is properly trapped and vented.

Adequate facilities shall be provided to air dry washed utensils and *equipment*. Storage facilities shall be provided to store cleaned and sanitized utensils and *equipment* at least 12" above the floor on fixed shelves or in enclosed cabinets protected from splash, dust, overhead plumbing or other contamination.

An adequate facility for preflushing or prescrapping shall be provided on the soiled dish side of the dishwashing machine.

Drainboards shall be provided, be of adequate size for the proper handling of utensils, and located so as not to interfere with the proper use of the warewashing facilities. Mobile dish tables may be acceptable for use in lieu of drainboards.

Chemical Warewashing

Chemical warewashing machines shall meet nationally recognized standards and be certified or classified by an ANSI accredited certification program. The installation must conform to applicable code requirements. Among the specific requirements for the installation of an *approved* chemical warewashing machine are the following:

- The chemical sanitizing feeder must meet nationally recognized standards and be certified or classified by an ANSI accredited certification program and be compatible with the specific make and model of machine in question.
- An *approved* chemical test kit for determining sanitizer strength shall be available and used.
- A visual flow indicator must be provided to monitor the operation of the sanitizing agent feeder. Other indication devices such as audible alarms may also be used. The flow indication devices must be installed so as to be conspicuous to the operator. A clear tube in which the chemical flows through is not acceptable.

Adequate facilities shall be provided to air dry washed utensils and *equipment*. Storage facilities shall be provided to store cleaned and sanitized utensils and *equipment* at least 6" above the floor, protected from splash, dust, overhead plumbing or other contamination; on fixed shelves; or in enclosed cabinets. The plan must specify location and facilities used for storing all utensils and *equipment*.

Warewashing / Utilizing Hot Water Sanitization

A commercial warewashing machine for mechanical warewashing utilizing hot water for sanitization must be in compliance with the standards of an ANSI accredited certification program. The installation and required accessories shall be in conformance with local applicable plumbing codes. An *approved* maximum registering thermometer or high temperature test papers shall be available and used.

If the detergent dispenser or drying agent dispenser is not equipped with an integral *backflow* prevention device, the installation point of the dispenser shall be below the *vacuum breaker* on the warewashing machine.

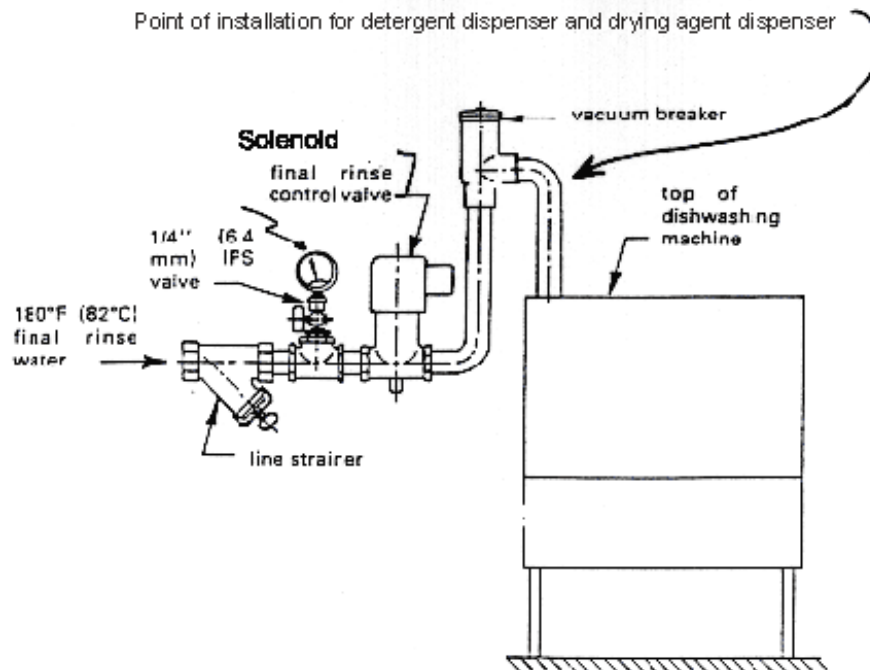

Recommended Warewashing Machine Installation

Part 9/ Determining Hot Water Supply Requirements

Worksheet Help			
Question #		Food Code & Food Law*	Guidance
80	Hot Water Using Fixtures	FC 5-103.11	Identify and list all <i>equipment</i> that will be supplied with hot water.
81-83	Proposed Water Heaters	FC 5-103.11	When multiple separate water heaters are provided indicate which water heater serves which fixtures. Unless otherwise stated, a gas water heater will be assumed to be 75% efficient. A higher efficiency water heater will lower the necessary water heater size.
<p>*FC = FDA 1999 Model Food Code. *FL = Michigan Food Law of 2000. To view the food code, food law and other fact sheets go to: http://www.michigan.gov/mda, keyword: MFLeduc, or call 517-373-1060 to request single free copies.</p>			

The hot water supply shall be sufficient to satisfy the continuous and peak hot water demands of the establishment. Hot water for handwashing shall be of a temperature of at least 110°F. Hot water for mechanical dishwashing must be 150°F-165°F for washing and 165°F-180°F for sanitizing. The temperature of the wash solution in spray-type warewashers that use chemicals to sanitize may not be less than 120°F. The water temperature for manual hot water sanitization must be at least 171°F. For purposes of sizing the hot water generating capability, assume a supply temperature requirement of 140°F to each fixture and to the mechanical dishwashing machines. In the absence of specific hot water usage figures for *equipment*, the following chart may be used to provide an approximation:

Equipment Type	Gallons Per Hour (GPH)	
	High	Low
Vegetable sink	15	15
Single pot sink	20*	15*
Double pot sink	40*	30*
Triple pot sink	60*	45*
Pre-rinse for dishes-shower head type	45	45
Bar sink-three compartment	20	20
Bar sink-four compartment	25	25
Chemical sanitizing glasswasher	60	60
Lavatory	5	5
Cook sink	10	10
Hot water filling faucet	15	15
Bain-marie	10	10
Coffee urn	5	5
Kettle stand	5	5
Garbage can washer	50	50
Nine and twelve pound clothes washer	45	45
Sixteen pound clothes washer	60	60
Employee shower	20	20
Mop Sink	15**	5**

High - To be used when multi-use eating utensils are utilized

Low - To be used where single service eating utensils are utilized.

*Gallons necessary to fill sink compartments can be calculated for a specific sink to make gallon per hour hot water estimates more accurate. A sample calculation for a 3 compartment sink is show below.

Calculate the Volume for each Sink Compartment

Volume = Length x Width x Depth 21" x 18" x 14" = 5292 cubic inches

Convert Cubic Inches to Cubic Feet

Cubic inches ÷ 1728 = cubic feet 5292 ÷ 1728 = 3.06 cubic feet

Convert Cubic Feet to Gallons

Cubic feet x 7.48 = gallons 3.06 x 7.48 = 22.89 gallons per compartment

Multiply x Number of Sink Compartments

22.89 x 3 sink compartments = 68.67 gallons to fill this 3 compartment sink once.

**Number of mop sinks in a facility may not be representative of water usage. Determine maximum number of times a mop bucket is filled per hour X 5 gallons per fill.

One way to estimate the projected hot water demand (gallons per hour final rinse) of mechanical warewashing machines, pot and pan washers and silverware washers, is to refer to the manufacturers' specification sheet for the particular make and model of the machine. MDA supports using a little as 70% of rated gph for facilities that use warewashing machines only occasionally.

To determine the required capacity and recuperative rate of the hot water generating *equipment*, it is necessary to calculate the demand in gallons per hour (gph) and determine the temperature rise required (assume an incoming water temperature of 40°F to the *food establishment* unless specific data are available) for each piece of *equipment*. These figures can then be converted to BTU's (for gas fired heaters) or KW (for electrical heaters). The required BTU or KW capacity of the heater will then be determined by adding up the individual BTU or KW requirements for each piece of *equipment*.

Note: To calculate BTU's or KW's, use the following formulas: (1 gallon of water = 8.33lbs)

For gas heaters (in BTU's):
$$\frac{\text{Gallons per hour of water} \times \text{Temp. rise} \times 8.33}{.75 \text{ (operating efficiency)}}$$

Required BTU =

For electrical heaters (in KW):
$$\frac{\text{Gallons per hour of water} \times \text{Temp. rise} \times 8.33}{3412 \text{ (BTU's per KW)}}$$

Required KW =

The following example will illustrate of the above method of approximating the size of the hot water heater needed for specified *equipment*:

<u>Equipment</u>	<u>Gallons Per Hour Demand from Chart</u>	<u>Temperature Required</u>	<u>Temp. Rise</u>
3 Compartment sink	60	140°F	100°F

$$\frac{60 \text{ (gph)} \times 100 \text{ degree temp. rise} \times 8.33}{.75 \text{ (operating efficiency)}} = 66,640 \text{ BTU's} \quad \text{OR}$$

$$\frac{60 \text{ (gph)} \times 100 \text{ degree temp rise} \times 8.33}{3412 \text{ (BTU's per KW)}} = 14.65 \text{ KW}$$

Assume an incoming water temperature of 40°F into the *food establishment*.

<u>Equipment</u>	<u>Gallons Per Hour Demand from Chart</u>	<u>Temperature Required</u>	<u>Temp. Rise</u>
Hand sink	5	110°F	70°F
$\frac{5 \text{ (gph)} \times 70 \text{ degree temp rise} \times 8.33}{.75 \text{ (operating efficiency)}}$		= 3,887 BTU's	OR
$\frac{5 \text{ (gph)} \times 70 \text{ degree temp rise} \times 8.33}{3412 \text{ (BTU per KW)}}$		= 0.85 KW	

This example assumes an incoming water temperature of 40°F into the *food establishment*.

For the above example, the total demand in BTU's or KW for the primary hot water heater would be:

3 Compartment sink=	66,640 BTU	or	14.65 KW
Hand sink=	3,887 BTU	or	0.85 KW
TOTAL DEMAND=	70,527 BTU	or	15.5 KW

<u>Equipment</u>	<u>Gallons Per Hour Demand from Mfgr.</u>	<u>Temp. Required</u>	<u>Temp. Rise</u>
Booster heater for hot water sanitizing Mechanical warewasher	64	180°F	40°F
$\frac{64 \text{ (gph)} \times 40 \text{ degree temp rise} \times 8.33}{.75 \text{ (operating efficiency)}}$		= 28,433 BTU's	
$\frac{64 \text{ (gph)} \times 40 \text{ degree temp rise} \times 8.33}{3412 \text{ (BTU per KW)}}$		= 6.2 KW	

For mechanical warewashing, assume a hot water demand based on a primary rise in temperature to 140°F. A booster heater must then be provided to boost the required gph demand an additional 40°F to attain the required 180°F final rinse temperature.

Note: Multiply the total gallons per hour by 34% then multiply by 1.1 to determine necessary minimum storage capacity. Regardless of the minimum shown by the calculation, a hot water storage capacity of 40-50 gallons is typically required.

Example: 189 gph needed for facility X 0.34 X 1.1= 71 gallons of storage necessary.

Part 10/ Finish Schedule

Worksheet Help			
Question #		Food Code & Food Law*	Guidance
17-31	Room Finishes	FC 6-1 FC 6-201.11-18	See information below.
*FC = FDA 1999 Model Food Code. *FL = Michigan Food Law of 2000. To view the food code, food law and other fact sheets go to: http://www.michigan.gov/mda , keyword: MFLeduc, or call 517-373-1060 to request single free copies.			

Interior Finishes:

1. Enamel coated steel (or other corrosion resistant surface)	9. Stainless steel
2. Filled block with epoxy painted or glazed surface	10. Aluminum
3. Commercial grade vinyl composition tile	11. Ceramic tile
4. Commercial grade vinyl composition sheets	12. Painted drywall
5. Fiberglass reinforced polyester (FRP) panel	13. Epoxy painted drywall
6. Vinyl clad acoustic tile	14. Plastic laminate
7. Poured seamless <i>sealed</i> concrete or poured synthetic	15. Acoustic tile
8. <i>Sealed</i> concrete	16. Quarry tile

The following chart provides guidance for floors, walls and ceilings. The numbers refer to the above table.

Kitchen	Floor	Wall	Ceiling
Food Preparation / Bar Serving Area	3, 7, 16	2, 5, 9, 10, 11, 13	6, 13, 14
Cooking	3, 7, 16	9, 10, 11	6, 13, 14
Warewashing Area	3, 7, 16	2, 5, 9, 10, 13	6, 13, 14
Food Storage	3, 4, 7, 8, 16	2, 5, 13	12, 15
Janitor Closet	7, 16	2, 5, 13	6, 13, 14
Garbage Room	3, 4, 7, 16	2, 5, 13	6, 13, 14
Walk-in Refrigerators & Freezers	3, 7, 9, 10, 16	1, 9, 10	1, 9, 10
Other Storage	3, 4, 7, 8, 16	12	12, 15
Dressing Rooms	3, 4, 7, 16	12	6, 12, 13, 14
Toilet Room	3, 4, 7, 16	2, 5, 13	6, 13, 14

Floors

- All floor coverings in food preparation, food storage, utensil-washing areas, walk-in refrigeration units, dressing rooms, locker rooms, toilet rooms and vestibules must be *smooth*, non-absorbent, easily cleanable, durable, and commercial grade. *Equipment* must not puncture or indent the floor. Anti-slip flooring may only be used in high traffic areas.
- Any alternate materials not listed in the above chart must be submitted for evaluation.
- There must be coving at base junctures that is compatible with both wall and floor coverings. The coving should provide at least 1/4 inch radius and 4" in height..
- Floor drains, floor sinks and the surrounding area must be easily accessible for cleaning.

Custom cabinetry shall be constructed of durable materials with surfaces that are smooth, non-permeable and light colored for easy cleaning. This includes the interior surfaces (i.e. beverage stations, salad or buffet units, service counters and the underside of open countertops).

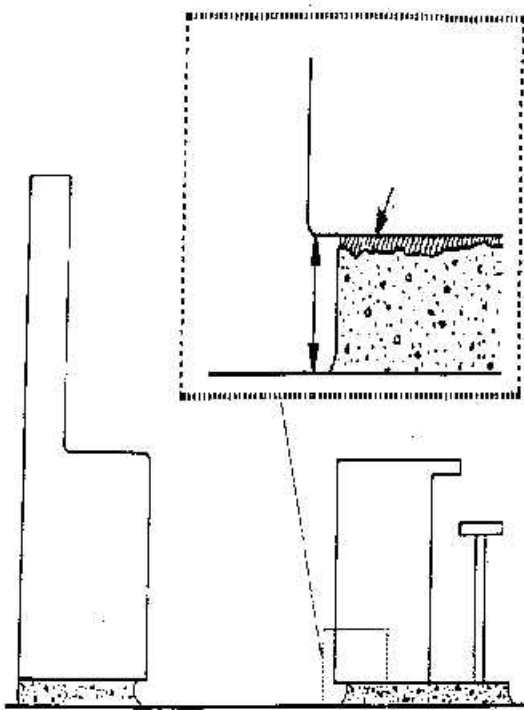

- Properly installed, trapped floor drains shall be provided in floors that are water-flushed for cleaning or that receive discharges of water or other fluid waste from *equipment*, or in areas where pressure spray methods for cleaning *equipment* are used. Floors should be sloped to the drain at least 1/8" per foot.
- Grouting should be non-absorbent and impregnated with epoxy, silicone, polyurethane or equivalent compound.
- All walk-in refrigeration units, either with prefabricated floors and without, should be installed in accordance with the manufacturers' installation requirements.

Walls

- The walls, including non-supporting partitions, wall coverings and ceilings of walk-in refrigeration units, food preparation areas, *equipment* washing and utensil washing areas, toilet rooms and vestibules shall be *smooth*, non-absorbent, and capable of withstanding repeated washing. Light colors are recommended for walls and ceilings. Studs, joists and rafters shall not be exposed in walk-in refrigeration units, food preparation areas, *equipment* washing and utensil washing areas, toilet rooms and vestibules. Where permitted, exposed studs, joists and rafters must be finished to provide an easily cleanable surface.
- All alternate materials not listed in the above chart must be submitted for evaluation.
- Glazed surfaces should be glazed block or brick, or ceramic tile. Grouting must be non-absorbent and impregnated with epoxy, silicone, polyurethane or an equivalent compound. Concrete block, if used, must be rendered non-porous and *smooth* by the application of an *approved* block filler followed by the application of an epoxy-type covering or equivalent. All mortar joints shall be only slightly tooled and suitably finished to render them easily cleanable.
- Joint finishes should be compatible with the wall structure. Voids should be eliminated at joints.

Ceilings

- Finishes shall be light-colored, *smooth*, non-absorbent and easily cleanable.

Part 11/ Toilet Facilities

Toilet facilities shall be installed according to law and shall be the number required by law. They shall be conveniently located and shall be accessible to employees at all times. Toilet facilities shall be accessible in accordance with the Americans with Disabilities Act (ADA) of 1990. Consult your local building department for requirements. Specific plumbing requirements are in the Michigan Plumbing Code, which adopts the International Plumbing Code 2000. The reviewing health agency will review the proposed facility for compliance with the plumbing code items that are related to food safety.

Toilets and urinals shall be designed to be easily cleanable and shall have integral *backflow* prevention devices as required by law. Toilet rooms shall be completely enclosed and shall have tight-fitting, self-closing doors and shall be vented to the outside if subject to odors.

Food facilities such as grocery stores, convenience stores and food service facilities may have rest rooms that open directly into the food preparation area. Other facilities, typically processing plants, must provide employee rest rooms that do not open into areas where food is exposed to airborne contamination, except where alternate means have been taken to protect against such contamination (such as double doors or positive air-flow systems).

A sign or poster that notifies *food employees* to wash their hands shall be provided at all handwashing sinks used by *food employees* and shall be clearly visible to *food employees*.

Part 12/ Plumbing and Cross-Connection Control

Worksheet Help			
Question #	Food Code & Plumbing Code*	Guidance	
45-79	Plumbing Cross-Connections	FC 5-202.13-14 FC 5-402.1 FC 5-402.11 IPC 608.16.2 IPC 802.11	The worksheet asks that a table be filled out showing what <i>backflow</i> or <i>backsiphonage</i> prevention devices or methods will be used. Below is an example of that table with the typical possible responses.
*FC = FDA 1999 Model Food Code. *IPC= International Plumbing Code. To view the food code, food law and other fact sheets go to: http://www.michigan.gov/mda , keyword: <u>MFLeduc</u> , or call 517-373-1060 to request single free copies.			

Typical possible correct responses are shown for the worksheet cross-connection table. It is recommended that your plumber or architect complete this table. Some responses are only correct under certain circumstances. For example, a 2 compartment sink would have to be direct connected if a garbage disposal were installed in the sink.

Fixture	Sewage Disposal			Water Supply				
	Air Gap	Air Break	Direct Connect	AVB	PVB	RPZ	Hose Bibb	Air Gap
45. Dishwasher	X	X	X*	X				X
46. Glasswasher	X	X	X*	X				X
47. Garbage grinder			X	X	X			X
48. Ice machines	X							
49. Ice storage bin	X							
50. Mop sink faucet								X
51. 3 compartment sink	X	X	X					X
52. Culinary (food preparation) sink	X							X
53. Other sinks, except handsinks	X	X	X					X
54. Steam tables	X			X				X
55. Dipper wells	X							X
56. Hose connections				X	X		X	
57. Refrigeration condensate drain lines	X							
58. Beverage dispenser with carbonator				DC w/ AV				
59. Water softener drain	X							
60. Potato peeler	X							X
61. Walk-in floor drain	X	X						
62. Chinese range	X			X	X	X		
63. Detergent feeder on faucet				X	X			X
64. Outside sprinkler or irrigation system				X	X	X		
65. Power washer						X		
66. Retractable hose reel					X	X		X
67. Toilet			X	X	Anti-siphon ballcock			
68. Urinal			X	X				
69. Boiler						X	DC w/ AV	
70. Bain-marie	X							X
71. Espresso machine		X					DC w/ AV	
72. Combi-style oven	X						DC w/ AV	
73. Kettle	X			X	X			
74. Rethermalizer	X				X			
75. Steamer	X							
76. Overhead spray rinse					X			X
77. Hot water dispenser				X				X

*with floor drain within 5'.

AVB=atmospheric *vacuum breaker*

PVB=pressure *vacuum breaker*

RPZ=reduced pressure principle *backflow* preventer

DC w/ AV= Double check valve with an atmospheric vent

Cross-Connections

A cross-connection is an ACTUAL or POTENTIAL link between the potable water supply and a source of contamination (*sewage*, chemicals, gas, etc.). A cross-connection can be a temporary or permanent direct connection, by-pass arrangement, jumper connection, submerged inlet, removable section, swivel or change-over device, etc. that could connect a potable system to a non-potable source. Ideally, it is best to not have any cross-connections, but in certain situations they are unavoidable. When an installation requires a cross-connection, it must be properly protected with an acceptable *backflow* prevention assembly or device to eliminate any potential for a reverse flow back into the potable water supply. An unprotected cross-connection threatens the health and safety of individuals and may contaminate food or beverage products utilizing water from that system.

Two Types of Cross-Connections:

Direct Connection: Is a physical connection between a potable and non-potable system. A direct pathway exists between the two separate systems for contamination to be transferred into the potable water system. An example of a direct connection is a pipe installed to connect a potable water line to a sewer line.

Indirect Connection: Is a situation in which, under "normal" conditions, a cross-connection does not exist. However, under "unique" circumstances a pathway for contamination can occur. The source of contamination may be a back-up, be blown across, siphoned, pushed, or diverted into a potable water supply. An indirect connection is only subject to *backsiphonage*.

Forces Acting on Cross-Connections

Some cross-connections are immediately obvious, but others can be subtle and difficult to find. Contamination occurs when the pressure between the water supply and another system (via some connection) are sufficient to transfer the contaminant into the water supply. These temporary reversals of pressure can be unpredictable.

Backflow

Backflow is a reversal in flow that is opposite to the expected or intended direction. The reversal in flow is undesirable. However, a properly protected system can remain safe. There are two types of *backflow*: "backpressure" and "backsiphonage".

Backpressure occurs when both systems (potable & non-potable) are under pressure (above atmospheric pressure). *Backflow* occurs when the non-potable system has greater pressure than the potable system. This pressure differential pushes the contaminant into the potable supply.

Backsiphonage occurs when the pressure in the water supply system drops below atmospheric pressure and the non-potable source is drawn or siphoned into the water supply. Back-siphonage can occur with either a direct or indirect connection and the systems can be either open or closed to the atmosphere. Principle causes include:

- Undersized sections of pipe can create an aspirator effect in the restricted area.
- A break or repair in a supply line can create a vacuum (as gravity drains the water out) on the elevated portions of the system above the effected area.
- A high water withdrawal, such as fire fighting or water main flushing, can create a vacuum. The withdrawal is more likely to create stronger negative pressure at the higher elevation of the system.
- A vacuum can be induced on the suction side of a booster pump, such as high-rise buildings and processing plants.

Physical Backflow Prevention Methods

Air Gap

An *air gap* is the most desirable method of *backflow* prevention. It is simple, economical, non-mechanical, fail safe, and can be used for potential backsiphonage and

backpressure applications. An *air gap* is the unobstructed vertical air space that separates the end of a supply line and the flood level rim of a receptacle. The receptacle may be a sink, coffee urn, steam kettle, floor drain, floor sink, etc. The *air gap* must be the greater of the two – a minimum of 1 inch or twice the diameter of the supply pipe.

The following are some *air gap* applications:

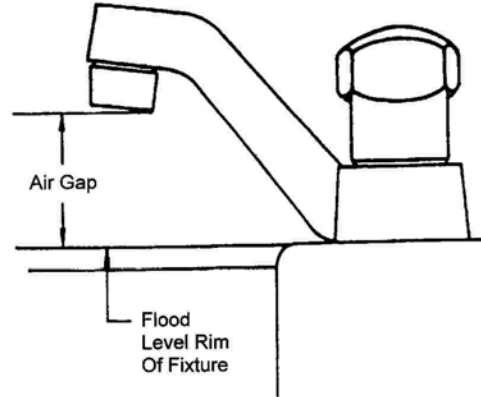
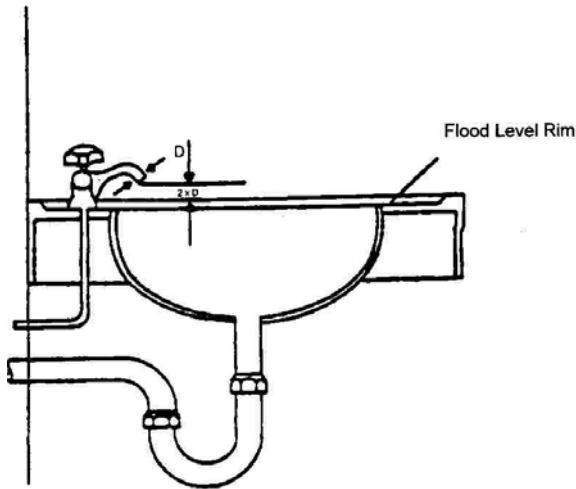

Air Gap And Effective Opening



Ice Cream Dipper Well



Water Fill to Steam Kettle

Mechanical Backflow Assemblies & Devices

The type of mechanical assembly or device selected must be appropriate for the degree of hazard and specific application. Some mechanical *backflow* preventers consist of single or multiple check valves that open from the flow pressure of the potable water. The valves are fabricated to seat tightly on a machined surface and, when closed, prevent any flow in the wrong direction. Some devices have air inlets or ports that are vented to the atmosphere to relieve any vacuum or negative pressure. All back flow devices must be installed so they are accessible for inspection and repair. All mechanical devices are required to be certified by the American Society of Sanitary Engineers (ASSE). The level of hazard is a consideration in the selection of the appropriate device.

High Hazard situations exist when there is an actual or potential connection for any toxic or infectious substance (contaminant) to be introduced into the water supply and may create a danger to health. Examples of contaminants include pesticides, chemicals, and infectious microorganisms.

Low Hazard situations exist when there is an actual or potential connection for a nontoxic substance (pollutant) to be introduced to the water supply and create a nuisance or be aesthetically objectionable to the water user. Examples of pollutants are turbidity, beverages, and food coloring.

Hose Bib Vacuum Breaker ASSE – 1011 (high or low hazard)



A hose bib *vacuum breaker* is installed on the end of a hose bib (sill cock, boiler drain, etc.) or anywhere a hose can be connected. It contains one spring loaded valve and an atmospheric vent that is controlled by a diaphragm seal. Installation & Use:

Shut-off valves must be located upstream from the *vacuum breaker*. Spring-loaded shut-off spray valves must be removed when the hose is not in active use. Each hose connected to a manifold or "Y" must be provided with its own device (i.e. county fairs, special events, etc. where several vendors may share one hose spigot).

Approved for high hazards, non-continuous pressure, and no potential backpressure.

Atmospheric Vacuum Breaker

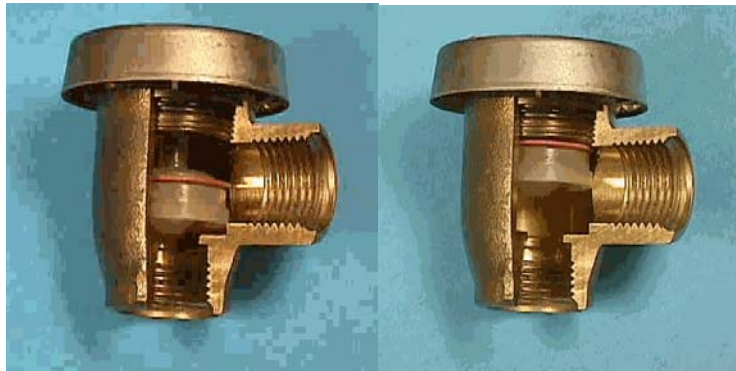

Closed Position
- drawing in air

Open Position
- allowing water to flow normally

The water supply serving the device in the upper left photo is turned off which allows the float valve to be in the "closed" position drawing in open air (arrows show air movement). The water supply in the upper right photo is turned on and shows the float valve in the "open" position (arrows show direction of water flow).

This device has an internal polyethylene or metal float valve that moves up and down on a shaft (not spring loaded). When the water is turned on, water moving in the normal open direction of flow lifts the float and causes the atmospheric vent to close (see "Open Position"). Shutting off the water causes the float to drop, the supply valve to close, and the atmospheric vent is opened (see

"closed position"). When a negative pressure occurs on the supply side, the float valve drops, closing off the supply, and opening the atmospheric vent. Installation and Use:

- The mushroom-shaped device must be installed vertically. The unit must be elevated at least 6 inches above the highest source of contamination "downstream" of the unit.
- All shut-off valves must be located "upstream" of the unit. The reason for this is that a valve located downstream of the unit maintains the device under constant pressure and the float valve in the open position. Over time, the float valve can stick in the open position and fail to prevent *backflow*. The unit cannot be tested after installation.
- *Approved* for high hazards, noncontinuous pressure, and no potential for backpressure.

Pressure Vacuum Breaker ASSE – 1020 (high or low hazard)



The pressure *vacuum breaker* is similar to the atmospheric *vacuum breaker* except that it has two test cocks and two gate or ball valves for testing the unit. It also has two positive seating (spring loaded) valves. The first check valve (supply side) is spring loaded for a closed position and "guards" the potable water side. When the water is turned on, the flow pushes it in the open position. The second check valve or air inlet valve (downstream side) is spring loaded for an open position to the atmosphere and only closes when the supply water is turned on. When the supply pressure drops below atmospheric pressure, the second check valve opens to the atmosphere and the first check valve closes. The device only provides protection against *backsiphonage*.

Installation and use:

- The unit must be installed at least 12 inches above the highest elevated inlet or fixture on its downstream side. The unit must have a shut-off valve on each side and two test cocks for testing.
- The device must be located to be accessible for testing and servicing.
- The unit is *approved* for high hazard, continuous pressure, and no backpressure potential. Valves may be located on the downstream side.

Backflow Preventers with Intermediate Atmospheric Vent ASSE 1012 and ASSE 1022 (low hazard)

ASSE-1012

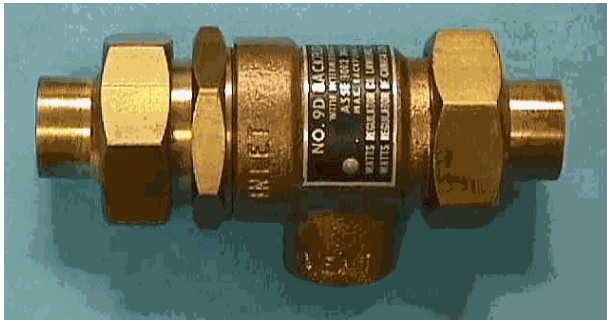

ASSE-1022



Used for carbonated beverages.

This device contains an atmospheric vent between two spring loaded check-valves. The valves close automatically under no-flow conditions. The atmospheric vent is controlled by a diaphragm seal that directly responds to the movement of the supply side of the check valve. As the water flow begins, the primary check opens and simultaneously frees the diaphragm seal to close off the atmospheric vent and then proceeds to open the secondary check valve (downstream side). The positive supply pressure holds the diaphragm seal in place to close off the atmospheric vent.

When zero pressure or back-siphonage conditions exists on the supply side, the primary check-valve closes under spring pressure and simultaneously pushes the diaphragm seal into position to form a tight seal between the valve and valve seat – opening the atmospheric vent and closing the secondary check valve.

Under backpressure conditions, the secondary check valve would close first. If the secondary check valve were to foul in the closed position, the primary check valve would close and the backpressure leakage would drain out through the atmospheric vent.

The ASSE 1022 device shown above includes an optional line filter (black add-on attachment).

Installation & Use:

- The unit can be installed horizontally and vertically and must not be located in a pit or a location subject to standing water. Under no circumstances can the relief port be plugged.
- Michigan code limits the use of this device for protection of low pressure untreated boilers (below 15 psi), carbonated beverage dispensers, and other low hazard applications.
- Valves may be located downstream of this device.

Double Check Valves ASSE 1015 (low hazard)



A double check valve *backflow* preventer consists of two check valves that are spring loaded in the closed position. The device does not have the added protection of an atmospheric vent and therefore is limited to the amount of protection it affords and how it can be used. Some codes and jurisdictions do not allow double check valves to be used for *backflow* protection.

Reduced Pressure Zone Backflow Prevention Assembly (RPZ) ASSE – 1013 (high or low hazard)

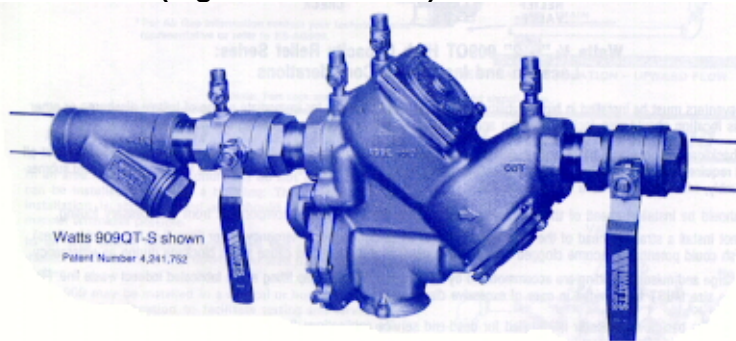

This type of mechanical device provides the maximum protection against both *backsiphonage* and backpressure.

Construction of the RPZ consists of two very sensitive and independent spring loaded check valves with a "reduced pressure zone" between them (at least 2 psi pressure differential from the supply pressure). The check valves are spring loaded to automatically close unless they are held open with the flow in the proper direction. As the water passes through the primary check valve, the water pressure will drop in the reduced pressure zone chamber (due to friction). Under normal conditions, the water will then continue on through the secondary check valve to the point of usage.

The reduced pressure zone contains a relief valve that drains to the atmosphere and is spring loaded for an automatic open position. The relief valve has the reduced pressure zone water on one side and the water supply pressure on the other side. To keep the relief valve closed, the supply pressure must exceed the RP zone pressure. Thus, it will spring open under any conditions causing the water pressure in the RP zone to approach or exceed the supply pressure. Also, when the relief valve opens, an air passage from the atmospheric vent is opened to satisfy any *backsiphonage* conditions. So, even if both check valves are fouled, the relief valve will continue to protect the supply.

Installation and use:

- Under no circumstances should the relief port be plugged.
- The RPZ is equipped with test cocks and gate valves for testing.
- The unit must be accessible for testing and service.
- *Approved* for high hazards, continuous pressure, backpressure, and back-siphonage.
- The unit may have valves located downstream and may be located lower than the potential source of contamination
- The relief port drain must be discharged by means of an *air gap* to a drain.

Two Single Check-Valves at Carbonator (Unapproved)



The water supply connection to carbonated beverage dispensers shall be protected against *backflow* by a double check valve with an intermediate atmospheric vent conforming to ASSE 1022 (see previous section for photo and description). The double check valve with an intermediate atmospheric vent device and the piping downstream therefrom shall not be effected by carbon dioxide gas. **The photo at left depicts an unapproved installation.**

Anti-siphon-type Water Closet Flush Tank Ballcock: ASSE- 1002 (low hazard)

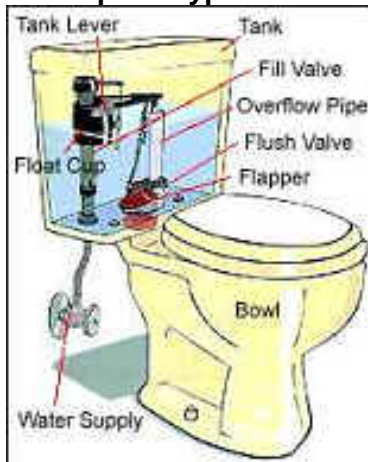

Installation and Use: Ballcock assembly must be installed above the overflow pipe high water level.

Typical Food Service Establishment Water Supply Cross-Connections



- **Pre-rinse or pre-flush hose:** This device is typically located at garbage grinders, mechanical dishwashing machines, and vegetable prep sinks. A spring normally keeps the end of the hose above the sink flood rim level to form an *air gap*. Worn springs allow the end of the hose to fall below the rim.
- **Lack of a hose bib vacuum breaker on hose connections:** Common locations for this problem are at janitor sinks, steam kettles, and outdoor faucets.
- **Valve installed at the end of a hose utilizing an atmospheric vacuum breaker for protection:** Correction involves either the removal of the valve or the installation of a pressure vacuum breaker.
- **Inlets which are or may become submerged:** Common problem areas may include submerged inlet in the toilet tank, garbage grinder, sink faucets, lawn irrigation system, hoses, water inlet to steam table / baine marie, water-cooled *equipment* discharged below flood rim of drain, water softening *equipment*, and chinese range.
- **Boilers:** Lack of protection for boilers that may be associated with building heating systems, food steamers, steam kettles, tilting skillets, and espresso machines. *Approved backflow* protection includes:
 - Boiler with no chemicals added: An in-line *backflow* protection device with an intermediate atmospheric vent for continuous pressure and potential backpressure.
 - Boiler with chemicals added: An RPZ *backflow* protection device or air-gap.

Air Gaps & Air Breaks for Drains & Waste

An indirect connection between food service *equipment* and the facility's drainage or wastewater disposal system is necessary to prevent waste water from backflowing into *equipment* where food, kitchenware, or utensils are retained.

Direct wastewater connection: A waste line or pipe from a fixture, receptacle, or device that discharges used water, waste materials, or *sewage* directly into the facilities drainage system.

Indirect wastewater connection: A waste line or pipe from a fixture, receptacle, or device that discharges used water, waste materials, or *sewage* into the facilities drainage system through an "*air gap*" or "*air break*".

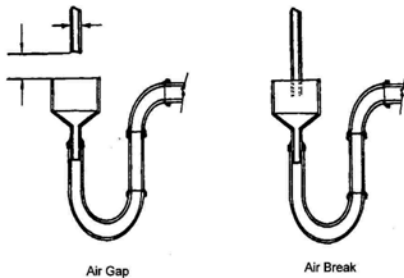

Air gap: is the unobstructed vertical space that separates the end of a supply line and the flood rim of a receptacle. The *air gap* must be the greater of either a minimum of one inch or twice the diameter of the supply pipe/

Air break: is a waste line or pipe from a fixture that discharges used water or liquid waste into another fixture or receptacle at a point below the flood rim level.



Examples of food service *equipment* requiring an **Air gap**:

- Relief valve for booster heater / water heater.
- Water-cooled condensers typically found at some ice machines or other refrigeration systems.
- Drain lines for food service *equipment* such as salad bar, ice machine, ice bin, cobra cup holder, steam kettle and steam table.
- Any sink compartment or *equipment* (i.e. ice cream dipper well) used for food. Note: Food sinks and *equipment* installed before 4/1/85 can have a direct connection until replaced.
- Brine tank drains from water softening *equipment*.
- Walk-in cooler floor drains that vertically discharge, as is typically found in a basement.

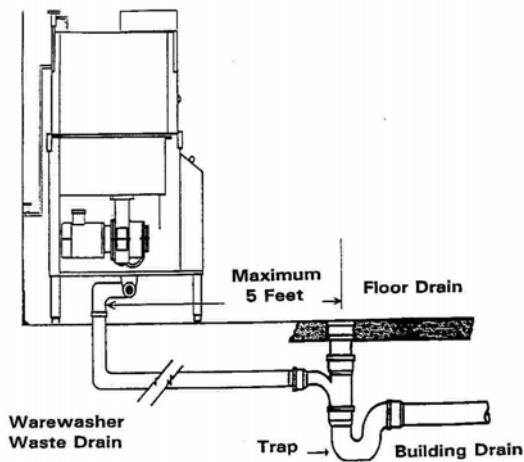

Examples of food service *equipment* requiring only an **Air break**:

- Floor drains in a walk-in cooler, provided a flapper valve is installed in the horizontally discharging drain line, such as is typically found in slab construction when a drain line discharges to a floor drain. Note: Vertical discharges must be air-gapped.
- Warewashing machines. An alternative is to direct connect the drain if there is a floor drain within 5' as shown below.
- Floor drains in a walk-in cooler, provided a flapper valve is installed in the floor drain line.

Examples of *food service establishment* plumbing devices that are allowed or required to have a **direct wasteline connection** to the facility's drainage system.

- **Direct Connection Required:** Sinks connected to grease interceptors (traps) and garbage grinders.
- **Direct Connection Allowed:** Hand sinks and warewashing *equipment* such as pot sinks and 3-compartment sinks. Warewashing machines may have a direct connection if there is a floor drain within 5' as shown above.

Notes:

- If any compartment of a warewashing sink is used for culinary purposes, then that sink compartment must be air-gapped.
- While directly connecting warewashing *equipment* is allowed, better public health protection is achieved by providing an indirect connection.
- When a garbage grinder is installed in a sink, a direct connection is required and that sink cannot be used for food.

Part 13/ Insect and Rodent Control

Worksheet Help			
Question #		Food Code & Food Law*	Guidance
36-42	Insect & Rodent Control	FC 6-202.15	See information below.
*FC = FDA 1999 Model Food Code. *FL = Michigan Food Law of 2000. To view the food code, food law and other fact sheets go to: http://www.michigan.gov/mda , keyword: MFLEduc, or call 517-373-1060 to request single free copies.			

Openings to the outside shall be effectively protected against the entrance of rodents. Openings to the outside shall be protected against the entrance of insects by the installation of tight fitting, self-closing doors; closed windows; self-closing serving windows at drive-thrus; screening; controlled air currents; vestibules; or other means *Approved* by the regulatory health authority. Screen doors shall be self-closing and screens for windows, doors, skylights, transoms, intake air ducts and other openings to the outside shall be tight fitting and free of breaks. Screening material shall not be less than sixteen mesh to the inch. Openings around pipes, conduit or wiring entering the building from the outside must be *sealed*.

Loading docks and delivery doors must be provided with effective air curtains or vestibules with self-closing doors to preclude the entrance of insects. It is recommended that outside lighting around loading areas and entrances be sodium vapor rather than mercury vapor to decrease insect attraction.

All foundations shall be rodent proof. Openings between the floor and bottom of outer doors shall be adequately flashed with rodent proof material to eliminate any opening.

Part 14/ Lighting

The light intensity shall be at least 110 lux (10 foot candles) at a distance of 75 cm (30 inches) above the floor, in walk-in refrigeration units, dry food storage areas and in other areas during periods of cleaning.

The light intensity shall be at least 220 lux (20 foot candles) at a surface where food is provided for consumer self-service such as buffets and salad bars or where fresh produce or packaged foods are sold or offered for consumption; inside *equipment* such as reach-in and under-counter refrigerators; at a distance of 75 cm (30 inches) above the floor in areas used for handwashing, warewashing, and *equipment* and utensil storage, and in toilet rooms.

The light intensity shall be at least 540 lux (50 foot candles) at a surface where a *food employee* is working with food or working with utensils or *equipment* such as knives, slicers, grinders, or saws where employees safety is a factor.

Darker colored walls and floors may require additional lighting.

Shielding such as plastic shields, plastic sleeves with end caps, shatterproof bulbs and/or other *approved* devices shall be provided for all artificial lighting fixtures located in areas where there is exposed food; clean *equipment*, utensils, and *linens*; or unwrapped single-service and single-use articles.

Heat lamps, where permitted, shall be protected against breakage by a shield surrounding and extending beyond the bulb, leaving only the face of the bulb exposed.

Part 15/ Ventilation

Worksheet Help			
Question #		Food Code & Food Law*	Guidance
87	Ventilation	FC 4-204.11 FC 4-301.14 FC 6-202.12 FC 6-304.11 FC 6-501.14 MMC 2000, Section 506	The worksheet asks for an air balance schedule. Ask your reviewing agency if they need this information for your project. This should typically show an adequate volume of air exhausted from each ventilation exhaust hood and an equal volume of heated make-up air being introduced to replace the air being exhausted. A copy of the cooking <i>equipment</i> ventilation plans submitted to the mechanical authority to obtain a mechanical permit should also be submitted to the reviewing health agency.
<p>*FC = FDA 1999 Model Food Code. *FL = Michigan Food Law of 2000. *MMC 2000 = Michigan Mechanical Code 2000 To view the food code, food law and other fact sheets go to: http://www.michigan.gov/mda, keyword: MFLeduc, or call 517-373-1060 to request single free copies.</p>			

Michigan Mechanical Code

All rooms shall have sufficient ventilation to keep them free of excessive heat, steam, condensation, vapors, obnoxious odors, smoke and fumes. Ventilation systems in Michigan must be installed according to the provisions of the Michigan Mechanical Code. The Michigan Mechanical code adopts by reference the International Mechanical Code and NFPA-96, a standard of the National Fire Protection Association. Michigan has one mechanical code that is used statewide. Mechanical plans must be submitted to the health agency conducting your review and to the local mechanical authority in the area where the facility is being built. The mechanical authority will issue any required permits. The mechanical code may be purchased from Michigan Department of Consumer and Industry Services, Bureau of Construction Codes. The order form is available at: http://www.michigan.gov/documents/cis_bcc_codes_36563_7.pdf or you may call 517-241-9325.

The mechanical code does not regulate the following types of *food establishment* ventilation systems:

- Any unit not in a fixed building, such as mobile units or some special transitory food units
- Ductless cooking units
- The venting of any *equipment* considered portable

Since the local mechanical authority will not be involved in issuing permits for these ventilation systems, you should work directly with your reviewing health agency on any necessary approvals.

Determining What *Equipment* Must be Vented

The reviewing health agency will often work with the local mechanical authority in determining if a particular piece of *equipment* must be placed under a ventilation hood. Michigan Department of Agriculture, Food and Dairy Division, will assist in reviewing *equipment* upon request. Specific equipment ventilation recommendations can be viewed at:

http://www.michigan.gov/mda/0,1607,7-125-1568_21390_21391_21400-60753--,00.html

Equipment that has historically never required a ventilation hood includes:

- Hot food holding units
- Low temperature cooking *equipment* such as Coney Island grills (for pre-cooked meats only), pretzel machines, and cabinet popcorn poppers.
- Electric fired, convection or non-convection, low-temperature enclosed insulated ovens (300° F maximum thermostatic setting).
- Chemical sanitizing warewashing machines and glass washing machines (maximum hot water temperature 140° F)
- Electric souv-laki machines (one only).
- Microwave and infrared sandwich or infrared pizza machines (for pre-packaged sandwiches and pre-packaged individual pizzas only).
- Under-counter hot water warewashing machines.
- Plate actuated electric cheesemelter.
- Waffle irons.
- Ductless Cooking Units. These units consist of commercial electric cooking appliances provided with recirculating systems that filter and introduce the air back into the room. These units must be UL Standard 197, Supplement SB listed or equivalent or have been reviewed and *approved* by MDA.

Air Balance Report and Smoke Test

The inspecting agency, at it's discretion, may require submission of an air balance report and may conduct a smoke test of all exhaust hoods prior to authorizing the facility to open. The air balance report and the smoke capture test are used to assure that the ventilation systems capture properly.

Part 16/ Dressing Rooms and Lockers

Worksheet Help			
Question #		Food Code & Food Law*	Guidance
11	Dressing Rooms	FC 6-305.11	Rooms or areas separate from food preparation, storage or service areas and separate from utensil washing or storage areas should be provided if employees will routinely change clothes within the establishment. Lockers or other suitable storage facilities shall be located in dressing areas. If dressing rooms are not required, separate facilities should be provided for the storage of coats, sweaters and other personal belongings.
<p>*FC = FDA 1999 Model Food Code. *FL = Michigan Food Law of 2000. To view the food code, food law and other fact sheets go to: http://www.michigan.gov/mda, keyword: MFLeduc, or call 517-373-1060 to request single free copies.</p>			

Part 17/ Garbage and Refuse Storage

Worksheet Help			
Question #		Food Code & Food Law*	Guidance
43	Outside Storage	FC 5-5 FC 6-202.110	Garbage and <i>refuse</i> containers, dumpsters and compactor systems located outside shall be stored on or above a <i>smooth</i> surface made of, or constructed of non-absorbent material such as 4" <i>sealed</i> concrete. Outdoor refuse areas shall be constructed in accordance with law and shall be curbed and graded to drain to collect and dispose of liquid waste that results from the refuse and from cleaning the area and waste receptacles. Garbage and <i>refuse</i> containers must have tight-fitting lids or covers.
44	Inside Storage	FC 5-5	Garbage or <i>refuse</i> storage rooms shall be constructed of cleanable, non-absorbent, washable materials and shall be insect-proof and rodent-proof.
*FC = FDA 1999 Model Food Code. *FL = Michigan Food Law of 2000. To view the food code, food law and other fact sheets go to: http://www.michigan.gov/mda , keyword: MFLEduc, or call 517-373-1060 to request single free copies.			

Part 18/ Special Transitory Food Units

A special transitory food unit (STFU) is a *food service establishment* that is licensed to operate throughout the state for any number of days, and is equipped and operates in a manner so as not to be required to return to a home base for resupply or cleaning.

This license was created to combine the old Transitory Food Units (TFUs), and hopefully, many of the temporary establishments. The desire was to lessen the burden many local health departments are facing with an ever-increasing number of temporary food units that typically need licensure each weekend. It is also expected that many units previously licensed as a mobile will apply for this type of food service license to avoid the requirements to return to a licensed commissary each night.

STFUs can be of many varied designs. They could be units designed for a motor home chassis, hot dog cart, covered trailer, tent, or other similar moveable structure.

How Does Licensure and Regulation Take Place?

I. Licensing jurisdiction

A. The owner of a proposed STFU can apply for licensure at any local health department or MDA regional office. These regulatory authorities must accept the application for licensure, and are obligated to properly and accurately process the application for the license.

B. The STFU owner will make this decision based on many different factors, which best suits their business interest.

II. Is a plan review required?

A. Basic requirement: A plan review is required for any newly constructed, altered, extensively remodeled, or converted STFU.

B. Generally, the STFU license applicant who wishes to apply previously *approved* plans, must apply for licensure at the local health department where the TFU plans were *approved* and are on file. Individual exceptions may allow acceptance of extra-jurisdictional plans, but only if the accepting jurisdiction agrees. Regardless, the standard operating procedures (SOPs) and menu review are still required.

C. A previously licensed mobile *food service establishment* (mobile FSE) that has gone through the plan review process may or may not be required to complete a plan review as an STFU. Generally, a change from a mobile FSE license to an STFU license means an operational change. If the change is significant, a plan review should be conducted, but the emphasis would be on menu and SOP as they relate to the *equipment*. If the operational changes are not significant – and the *approved* plans are still on file and there is no significant menu or *equipment* change – then a new plan review would not be required.

D. A previously licensed temporary *food service establishment* or a mobile FSE without prior plan review and approval. These operations are required to have plans, menus, and SOPs reviewed and *approved* before licensure.

E. All new food service operations. A plan, menu, and SOP review and approvals are required before licensure.

F. For all above situations:

- i. A pre-operational inspection must be done after construction is completed and must be based on *approved* plans.
- ii. No fee is collected for a pre-operational inspection. It is included in the license application fee.
- iii. Subsequent year licensing must be done by original licensing jurisdiction to preserve inspection history and construction plans. If the STFU owner wishes to change licensing jurisdiction, an application for a new license and a new plan review would be required.

III. Plan review considerations/ The 1999 FDA Food Code applies as applicable:

A. Floors – acceptable flooring can include asphalt, concrete, dirt or gravel if covered with removable, cleanable mats, duckboards or similar materials. Protection from weather, windblown dust and/or debris; overhead contamination.

B. Overhead protection is required.

C. An STFU must provide protection of its operation by construction or location if needed.

D. Construction of walls and ceilings:

- i. Surfaces shall be *smooth* and easily cleanable or easily replaceable (tarps, canvas, screening, painted surfaces, plastic sheeting, etc.)
- ii. Unit must be capable of being completely protected from flying insects with screening, air curtains, self-closing doors, etc.
- iii. For operation at a location or time when insects are not present, outer openings need not be protected.
- iv. Mechanical ventilation
- v. Necessary if needed to keep unit free of smoke, steam, fumes, excessive heat. (Food Code 6-304.11).
- vi. Open or screened walls with adequate cross ventilation would preclude the necessity of mechanical ventilation.

E. Plumbing Issues

- i. Sinks for warewashing; if other than a three-compartment sink:
- ii. Two compartment sinks if *approved* per SOP
- iii. Separate portable basins if *approved* per SOP

- F. *Equipment* protection
 - i. *Air breaks/gaps* apply
 - ii. Potable water protection
 - iii. Submerged inlets must be protected (no hidden plumbing)
 - G. Service sinks
 - i. Service sinks may be installed in the unit
 - ii. Service sinks, if not in the unit, shall be provided and conveniently located exterior to the unit (within the boundaries, as necessary, of the event location or at adjacent building with permission).
 - H. Toilet facilities
 - i. Restroom must be convenient and accessible during all hours of operation when exterior to the unit (within the boundaries of, as necessary, of the event location or at adjacent building with permission).
 - ii Restrooms shall be equipped with a working, properly supplied handwash sink.
 - I. SOPS required to cover five basic areas:
 - i. *Sewage* disposal
 - ii Water sources
 - iii. Employee health and hygiene
 - iv. Five critical control points (cook, cool, reheat, cold holding, hot holding)
 - v. Unusual situations which need extra planning and control, such as batch utensil washing; easily replaceable flooring or temporary screening
 - J. Menu submittal to determine if *equipment*, design and space layout is appropriate for type and complexity of menu item and their preparation.
 - K. Handwash facilities required, except as noted in Food Code 5-203.11(c)
 - i. Handwashing facilities must be supplied with tempered running water. Water can be supplied either under pressure or by gravity.
 - ii. Facilities can include lavatory with mixing faucet; or portable closed insulated container with free flow valve supplied with suitable sized waste catch container; or hand cleaning methods when *approved* by licensing jurisdiction, such as alcohol wipes with limited food preparation, when covered by a SOP.
 - L. STFUs must carry on board the following items of information:
 - i. *Approved* SOPs
 - ii. *Approved* menu
 - iii. Receipt showing necessary fees paid
 - iv. License
 - v. Copies of all inspections
- IV. Fees
- A. Plan review (if required) set by the local jurisdiction if done by the local health department or \$177.00 if done by an MDA regional office
 - B. License \$122.00 statewide – includes \$30.00 state surcharge and \$5.00 education fund.
 - C. Operational inspections (2) \$90.00 each, statewide (total of \$180.00) to be kept by the jurisdiction conducting the operational inspections.
- V. First operational inspection
- A. Fee - \$90.00 to agency conducting the inspection.
 - B. Inspection agency – dependant on the location of the event.
 - i. State and county fairs = MDA
 - ii. Other locations/events = local health department
 - C. STFU notifies the appropriate agency in writing four days before the event.
 - D. STFU mails copies of the inspection report to the licensing jurisdiction within 30 days.
 - E. Can be combined with the pre-opening inspection if the unit is in operation and serving food.

VI. Subsequent event operations

- A. STFUs must send a notice by mail, four days prior to serving, the local health department jurisdiction in which food will be served (includes MDA Regional Office).
- B. Local health departments can inspect the unit while it is operating in their jurisdiction – no fee can be collected. STFUs must mail copies of all such inspection reports to the licensing jurisdiction within 30 days. The jurisdiction conducting the inspection shall also send a copy to the licensing jurisdiction.

VII. Second operational inspection

- A. STFUs must request inspection by the jurisdiction in which operation will take place – either local health department or MDA (if fair).
- B. \$90.00 fee is retained by the inspecting jurisdiction. STFUs mail a copy of the inspection to the licensing jurisdiction within 30 days.

VIII. Enforcement

- A. Because of mobility of STFUs, critical violations must be corrected at the time of inspection.
- B. If critical violations are not corrected immediately, a notice of this is sent by the inspecting jurisdiction to the licensing jurisdiction for consideration of appropriate enforcement action. This is necessary because the jurisdiction, which issues the license is responsible for enforcement action against the licensee.
- C. If the STFU fails in any of the requirements of Food Law of 2000, section 6137, the STFU would not be eligible to be licensed as a STFU the next year.

Part 19/ Non-Smoking Area and Choking Poster Requirements

Nonsmoking Areas in Food Service Establishments

Nonsmoking areas are regulated by section 12905 of Act 368 of Public Acts of 1978, being section 333.12905 of the Michigan Compiled Laws, as amended by Act 96, Public Acts of 1986; Act 297, Public Acts of 1988; and Act 242, Public Acts of 1993.

Requirements

- All public areas of a *food service establishment* including bathrooms, coatrooms, entrances, or other areas used by a patron shall be nonsmoking.
- Establishments with fewer than 50 seats and private clubs, regardless of the number of seats, may designate up to 75% of its seating capacity for smokers.
- Establishments with 50 or more seats may designate up to 50% of its *seating capacity* for smokers.
- Seats required for nonsmokers shall be identified as nonsmoking (table tents will be sufficient) and shall be in close proximity to each other.
- Requirements include food services within malls.

Exemptions

- Public area does not include the lobby, waiting room, hallways and lounge areas.
- Requirements do not apply to:
 - A private club that is serviced by a catering kitchen. (Catering kitchen may be on or off the premise).
 - A separate room in a food establishment used for private banquets.
 - A facility owned and operated by a fraternal organization serving only members and guests.
 - Seats located at a bar or seats at tables that are located adjacent to a bar (lounge area), if meals are not served at those tables.

Note: For the purposes of the Act, meals shall not include snacks, hors d'oeuvres, or appetizers served.

Recommendations

Nonsmoking seats must be clearly identified as nonsmoking. This may be accomplished by a sign or other suitable device such as area or table signs or table tents. The sign or device should bear the wording "NO SMOKING IN THIS AREA." The sign devices must be clearly visible and readable. Ashtrays should be removed from these tables. It is not required to post a sign at the entrance indicating availability of a nonsmoking area.

Enforcement

Complaints should be in writing and submitted to the local health department or MDA regional office having jurisdiction. Upon receipt of a complaint, the responsible agency shall investigate the complaint within 5 days to determine compliance. Failure to comply within two days may result in enforcement action.

Antichoking Poster

Section 6141 of the food law of 2000, states that:

(1) A food service establishment in which solid foods are sold and consumed on the premises shall prominently display a poster in the kitchen area of the food service establishment diagramming and explaining the antichoking techniques safe for both adults and children approved by the department for dislodging foreign obstacles caught in the throat of a choking person.

(2) This section does not impose a duty upon the owners or employees of a food service establishment to apply antichoking techniques.

Part 20/ Definitions

Defined words are in italics in the text of the document

Acceptable food equipment means food *equipment* that is deemed to be in conformance with Food Code provisions such as *equipment* that is certified or classified for sanitation by an American National Standards Institute (ANSI)-accredited certification program. Such *equipment* is deemed to comply with Parts 4-1 and 4-2 of the Food Code.

Under ANSI document CA-1 ANSI Policy and Criteria for Accreditation of Certification Programs, it has been stipulated that::

“For food *equipment* programs, standards that establish sanitation requirements shall be specified government standards or standards that have been ratified by a public health approval step. ANSI shall verify that this requirement has been met by communicating with appropriate standards developing organizations and governmental public health bodies.”

The term “certified” is used when an item of food *equipment* has been evaluated against an organization’s own standard. The term “classified” is used when one organization evaluates an item of food *equipment* against a standard developed by another organization.

Air Break means a piping arrangement in which a drain from a fixture, appliance, or device discharges indirectly into another fixture, receptacle or interception at a point below the flood level rim. The connection does not provide an unobstructed vertical distance and is not solidly connected but precludes the possibility of *backflow* to a potable water source.

Air Gap means the unobstructed vertical distance through the free atmosphere between the lowest opening from any pipe or outlet supplying fixture, or other device, and the flood level rim of the receptacle. The vertical physical separation shall be at least two times the inside diameter of the water inlet pipe above the flood rim level but shall not be less than one inch.

Approved means acceptable to the *regulatory authority* based on a determination of conformity with principles, practices, and generally recognized standards that protect public health.

Backflow means the flow of water or other liquids, mixtures, or substances into the distributing pipes of a potable supply of water from any source or sources other than its intended source. Back-siphonage is one type of *backflow*.

Backflow Preventer means a device or means to prevent *backflow*.

Back-siphonage means the flowing back of used, contaminated, or polluted water from a *plumbing fixture* or vessel or other sources into a potable water supply pipe due to a negative pressure in such pipe.

Equipment means an article that is used in the operation of a *food establishment* such as a freezer, grinder, hood, ice maker, meat block, mixer, oven, reach-in refrigerator, scale, sink, slicer, stove, table, temperature measuring device for ambient air, vending machine, or warewashing machine. "*Equipment*" does not include items used for handling or storing large quantities of packaged foods that are received from a supplier in a cased or overwrapped lot, such as hand trucks, forklifts, dollies, pallets, racks, and skids.

Food Employee means an individual working with unpackaged food, food *equipment* or utensils, or food-contact surfaces.

Food Establishment means an operation where food is processed, packed, canned, preserved, frozen, fabricated, stored, served, sold or offered for sale. *Food establishment* includes a food processing plant, a *food service establishment*, and a retail grocery. *Food establishment* does not include any of the

following:

- A charitable, religious, fraternal or other non-profit organization operating a home-prepared baked goods sale or serving only home-prepared food in connection with its meetings or as part of a fund-raising event.
- An inpatient food operation located in a health facility or agency subject to licensure under article 17 the public health code, MCL 333.20101 to 333.22260.
- A food operation located in a prison, jail, state mental institute, boarding house, fraternity or sorority house, convent or other facility where the facility is the primary residence for the occupants and the food operation is limited to serving meals to the occupants as part of their living arrangement.

Food Processing Plant means a *food establishment* that processes manufactures, packages, labels, or stores food and does not provide food directly to a consumer.

Food Service Establishment means a fixed or mobile restaurant, coffee shop, cafeteria, short order cafe, luncheonette, grill, tearoom, sandwich shop, soda fountain, tavern, bar, cocktail lounge, nightclub, drive-in, industrial feeding establishment, private organization serving the public, rental hall, catering kitchen, delicatessen, theater, commissary, or similar place in which food or drink is prepared for direct consumption through service on the *premises* or elsewhere, and any other eating or drinking establishment or operation where food is served or provided to the public. *Food service establishment* does not include any of the following:

- A motel that serves continental breakfasts only.
- A food concession.
- A bed and breakfast that has 10 or fewer sleeping rooms, including sleeping rooms occupied by the Innkeeper, 1 or more of which are available for rent to transient tenants.
- A bed and breakfast that has at least 11 but fewer than 15 rooms for rent, if the bed and breakfast serves continental breakfasts only.
- A child care organization regulated under 1973 PA 116, MCL 722.111 to 722.128, unless the establishment is carrying out an operation considered by the director to be a food service establishment.

Linens means fabric items such as cloth hampers, cloth napkins, table cloths, wiping cloths, and work garments including cloth gloves.

Portable means 30 pounds or less, no dimensions exceeding 36" and no fixed utility connections.

Physical facilities means the structure and interior surfaces of a *food establishment* including accessories such as soap and towel dispensers and attachments such as light fixtures and heating or air conditioning system vents.

Plumbing fixture means a receptacle or device that:

- Is permanently or temporarily connected to the water distribution system of the *premises* and demands a supply of water from the system; or
- Discharges used water, waste materials, or *sewage* directly or indirectly to the drainage system of the *premises*.

Plumbing system means the water supply and distribution pipes; *plumbing fixtures* and traps; soil, waste, and vent pipes; sanitary and storm sewers and building drains, including their respective connections, devices, and appurtenances within the *premises*; and *water-treating equipment*.

(a) **Potentially hazardous food** means a food that is natural or synthetic and that requires temperature control because it is in a form capable of supporting:

- (i) The rapid and progressive growth of infectious or toxigenic microorganisms;
- (ii) The growth and toxin production of *Clostridium botulinum*; or
- (iii) In raw shell eggs, the growth of *Salmonella enteritidis*.

(b) **Potentially hazardous food** includes an animal food (a food of animal origin) that is raw or heat-

treated; a food of plant origin that is heat-treated or consists of raw seed sprouts; cut melons; and garlic and oil mixtures that are not acidified or otherwise modified at a food processing plant in a way that results in mixtures that do not support growth as specified under Subparagraph (a) of this definition.

(c) **Potentially hazardous food** does not include:

- (i) An air-cooled hard-boiled egg with shell intact;
- (ii) A food with an a_w value of 0.85 or less;
- (iii) A food with a pH level of 4.6 or below when measured at 24°C (75°F);
- (iv) A food, in an unopened hermetically sealed container, that is commercially processed to achieve and maintain commercial sterility under conditions of nonrefrigerated storage and distribution; and
- (v) A food for which laboratory evidence demonstrates that the rapid and progressive growth of infectious or toxigenic microorganisms or the growth of **S. enteritidis** in eggs or **C. botulinum** can not occur, such as a food that has an a_w and a pH that are above the levels specified under Subparagraphs (c)(ii) and (iii) of this definition and that may contain a preservative, other barrier to the growth of microorganisms, or a combination of barriers that inhibit the growth of microorganisms.

(vi) A food that may contain an infectious or toxigenic microorganism or chemical or physical contaminant at a level sufficient to cause illness, but that does not support the growth of microorganisms as specified under Subparagraph (a) of this definition.

Premises means:

- The physical facility, its contents, and the contiguous land or property under the control of the permit holder
- The physical facility, its contents, and the land or property if its facilities and contents are under the control of the permit holder and may impact *food establishment* personnel, facilities, or operations, if a *food establishment* is only one component of a larger operation such as a health care facility, hotel, motel, school, recreational camp, or prison.

Ready-To-Eat Food

(a) "*Ready-to-eat food*" means food that is in a form that is edible without washing, cooking, or additional preparation by the *food establishment* or the consumer and that is reasonably expected to be consumed in that form.

(b) "*Ready-to-eat food*" includes:

- (i) *Potentially hazardous food* that is unpackaged and cooked to the temperature and time required for the specific food under Subpart 3-401;
- (ii) Raw, washed, cut fruits and vegetables;
- (iii) Whole, raw fruits and vegetables that are presented for consumption without the need for further washing, such as at a buffet; and
- (iv) Other food presented for consumption for which further washing or cooking is not required, and from which rinds, peels, husks or shells are removed.

Refuse means solid waste not carried by water through the sewage system.

Regulatory Authority means the local, state, or federal enforcement body or authorized representative having jurisdiction over the *food establishment*.

Sealed means free of cracks or other openings that allow the entry or passage of moisture.

Seating Capacity means the actual number of seats for patrons in a *food service establishment*. Seating capacity does not include seats located at a bar or seats at tables that are located adjacent to a bar, if meals are not served at those tables.

Sewage means liquid waste containing animal or vegetable matter in suspension or solution and may include liquids containing chemicals in solution.

Smooth means:

- A food-contact surface having a surface free of pits and inclusions with a cleanability equal to or exceeding that of (100 grit) number 3 stainless steel;
- A nonfood-contact surface of *equipment* having a surface equal to that of commercial grade hot-rolled steel free of visible scale; and
- A floor, wall, or ceiling having an even or level surface with no roughness or projections that render it difficult to clean.

Vacuum Breaker. See **Backflow Preventer.**

References

The following is a list of reference materials that users of the Plan Review Manual may find useful to more fully understand the complexities of facility plan review. These references contain suggested formulas in addition to the ones included in the preceding plan review guide.

Baraban, Regina S. and Joseph F. Durocher, *Successful Restaurant Design*, New York, NY: Van Nostrand Reinhold.

Barnes, James D., *Manual of Recommended Practice for Ventilation in Food Service Establishments*, National Environmental Health Association.

Birchfield, John C., *Design and Layout of Foodservice Facilities*, New York, NY: Van Nostrand Reinhold, 1984.

Food and Drug Administration, *Food Code 1999*, National Technical Information Service, Springfield, VA.

Kazarian, Edward A., *Foodservice Facilities Planning*, Third Edition, Copyright Van Nostrand Reinhold, New York, 1989.

NAFEM, National Association of Food *Equipment* Manufacturers, *Introduction to the Foodservice Industry* (Kitchen Design).

North American Association of Food *Equipment* Manufacturers, *An Introduction to the Foodservice Industry*, First Edition, 1996.

Slavato, J.A., *Environmental Engineering & Sanitation*, Fourth Edition, Copyright John Wiley & Sons, Inc., United States and Canada, 1992.

Scrieven, Carl and James Stevens, *Food Equipment Facts*, Troy, NY: Conceptual Design, 1980 or latest printing (or equal publication).

Stipanuk, David M. and Roffman, Harold, *Hospitality Facilities Management and Design*, American Hotel and Motel Association, Educational Institute, 1992.

Acknowledgements

This document is a modification of the FDA Plan Review Guidebook. The original FDA document can be viewed at: <http://vm.cfsan.fda.gov/~dms/prev-toc.html>

Original revisions to the FDA guidebook completed in 2002 by:

Local Public Health:

- Barry Hugo, Bay County Health Department
- Rod McNeill, Genesee County Health Department
- Al Kramer, RS, Plan Review Specialist, Kent County Health Department
- Al Knowles, Lenawee County Health Department
- Gary Green, CFSP, Mid-Michigan District Health Department
- Rodney Blanchard, Monroe County Environmental Health Division
- Penney Massey, Northwest Michigan Community Health Agency
- Kent Singer, RS, Tuscola County Health Department
- Alan Hauck, RS, Washtenaw County Health Department
- Phyllis Ficzytz, Wayne County Health Department
- Brian Cecil, Jackson County Health Department

Industry:

- Ed LaClair, BS, MS, RS, Tricon Corporation

State:

- Susan Trombley, Region 7, Michigan Department of Agriculture
- Byron Beerbower, Food Inspection Program Coordinator, Michigan Department of Agriculture
- Kevin Besey, RS, MPA, DAAS, Plan Review Specialist, Michigan Department of Agriculture

The original FDA guidebook prepared by:

The Northeast Region Plan Review Development Committee for the Conference for Food Protection. The following individuals and/or organizations are to be recognized for their invaluable contributions:

Federal:

- John P. Schrade, U.S. Food and Drug Administration, Northeast Region, Director of State Programs.
- Karen Coscarelli-Allmond, U.S. Food & Drug Administration, Office of Regulatory Affairs, Division of Human Resource Development.

State:

- Frederick (Rick) Petersen, Stamford, Connecticut Department of Health.
- Northeast Region Plan Review Development Committee.
- South Carolina Department of Health & Environmental Control.
- Todd Stephens, South Carolina Department of Health & Environmental Control.
- Roger Fortman, North Carolina Dept of Health, Food, Lodging and Institutional Sanitation Branch.

Other:

- Conference for Food Protection Plan Review Committee.
- D.L. Lancaster, Consultant, Ann Arbor, Michigan.